

LAMOR

# Product Reel

Solutions for Selected Scenarios

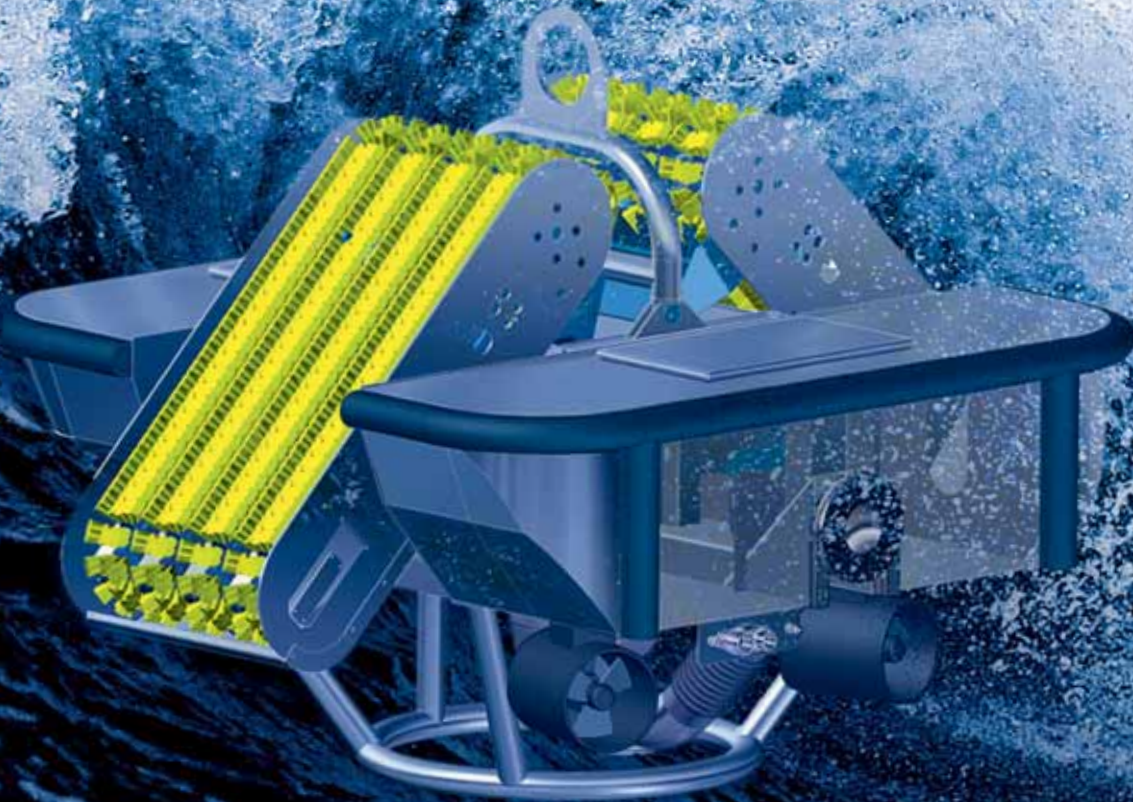



# Your oil spill solution expert

Lamor (Larsen Marine Oil Recovery) Corporation offers solutions for optimal oil spill response and recovery. With offices, staff and equipment strategically located around the world, Lamor is able to deploy on scene rapidly and effectively to best serve the environmental needs of governments, corporations and the general public, minimizing environmental footprints and salvaging eco-systems.

The company develops, manufactures, and supplies best available technology oil spill recovery equipment and services. Included in its portfolio of solutions, Lamor offers contingency planning, risk assessments, equipment maintenance and service coupled with training.

Lamor's headquarters is located in Finland, with 100 percent owned subsidiaries in the US, China and UK and joint-ventures in Russia, UAE and Oman. Moreover, Lamor has agent and distributor networks in over 90 countries. During the past 20 years, the company has sold equipment to more than 120 countries.



# Contents

	Introduction: Lamor Products	4
	Solutions for Selected Scenarios	6
1	Skimmers	
	Skimmer Systems Small	8
	Skimmer Systems Medium	14
	Skimmer Systems Large	16
2	Umbilical Hose Reel	30
3	Oil Booms	32
	Accessories	41
4	Pumps	44
5	Power-packs	46
6	Containerized Systems	52
7	Landing Crafts, Workboats and Oil Recovery Vessels	58
	Table of Conversions	70



# Lamor Products



Lamor is committed to oil spill response, recovery and clean-up operations worldwide.

We provide expertise coupled with solutions that protect the environment and our ecosystems. Our in-depth knowledge and investment in technologically advanced oil clean-up response equipment has a proven track record in all scenarios and climatic conditions.

**Our patented and certified solutions guarantee reliable and efficient oil recovery operations in any environment** and our training programs are accredited by the Nautical Institute in accordance with MCA and DTI certified training standards. We provide IMO Level 1-3 Oil Spill Responder training courses as well as tailored training programs in accordance with our customers' specific needs.

Lamor is ISO 9001 certified and moreover, each product is individually capacity certified at our own R&D and testing facilities in accordance with ASTM and MAX standards that are inspected and certified by Bureau Veritas.

**We have extensive experience in cooperation with governmental agencies worldwide** i.e. Swedish Coastguard, North American authorities and representative agencies, Russian authorities and ministries, European Union environmental administrations, European Maritime Safety



Agency (EMSA), Chinese governmental and maritime departments and Middle Eastern environmental and representative agencies in several countries.

Members of Lamor Response Team (LRT) have acted as on scene commanders at numerous oil spill incidents and the LRT has extensive managerial knowledge and expertise of oil spill accidents in various environments and weather conditions such as offshore, on land, Arctic and desert climate.

We continuously invest in our products and solutions, i.e. oil spill response (OSR) technology. Lamor has in-depth expertise and knowledge in oil spill clean-up operations, which includes the use of best available technology (BAT). Investments in R&D are pivotal for effective and efficient oil spill scenarios.

Lamor oil spill clean-up products can be used anywhere and anytime, no matter what terrain and climate (Arctic, desert, offshore etc.). The products are long-lasting, user friendly with low maintenance and service requirements.

All Lamor skimmers and pumps are capacity tested and certified by Bureau Veritas, which is a continuous process with new products and solutions being developed. Lamor Production has received ISO Standard 9001:2000 certification for its Quality Management System.

Lamor's product portfolio range includes several hundred various sizes, capacities and functions. Attached are just a few examples of Lamor's extensive oil clean-up equipment. Moreover, Lamor's product portfolio, besides products, offers expertise and knowledge in certified training, contingency planning, service and maintenance, LRT, etc.

**Please contact Lamor to identify the ideal solution pending your needs and requirements.**

## Oil Spill Response Equipment



Skimmer small   Skimmer medium   Skimmer large   Pump



Power Pack   Storage   Trailers   Vessels   Services

**These icons are used in the text to describe products and usage areas.**

## Preferred usage areas



Arctic   Offshore   Nearshore Harbor   River   Shoreline   Pond   Industrial   Land

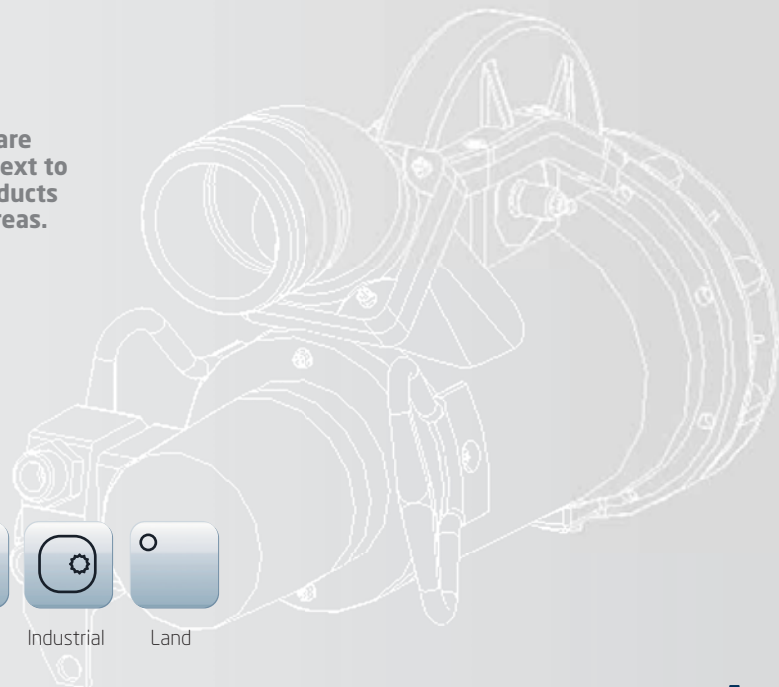

# Solutions for Selected Scenarios



## Arctic Applications

Lamor offers a full range of Arctic oil recovery equipment. Proven technologies are operational on ice breakers in e.g. the Baltic Sea and are used in many Arctic oil ports.

Exploration and oil extrapolation in the Arctic Ocean is surging ahead, and the climatic conditions can be brutal in that region. Lamor has years of experience in Arctic oil response and recovery operations.

Moreover, Lamor has invested significantly in R&D to find new and effective oil clean-up solutions. In addition to having all our skimmers, pumps and power-packs capacity tested by Bureau Veritas in Finland, we have also started an extensive vetting program for our next generation skimmers at Ohmsett in New Jersey, USA.



## Offshore and Shipboard Systems

The Lamor Vessel Mounted Advancing Oil Recovery Systems are based on the proven chain brush conveyor technology that offers the highest possible performance and safety for offshore oil spill recovery operations.

Deployment of the recovery system makes the entire vessel an "oil slick processing system". Proven technology, Lamor's shipboard systems have been installed on over 1000 vessels and work boats around the world.

In addition to the shipboard systems, Lamor also offers a wide range of offshore skimmers and heavy duty oil booms.

Whatever the scenario or environment, Lamor provides the right oil spill solution for the most efficient oil spill response. Lamor solutions include a complete range of skimmers, oil booms, pumps, power packs, landing crafts, workboats, storage and ancillary equipment.



### Harbor, River and Shoreline Applications

Containerized harbor systems are custom-made to accommodate specific conditions. Each harbor faces different conditions due to location, currents, swells, tides and products handled.



Our experience allows us to accommodate each harbor with the proper customized solution.



Rapid response time is essential to perform effectively in river clean-up operations. Lamor offers specially designed, fast, current-resistant booms and high flow skimmers with debris-handling capabilities.

Lamor beach and shoreline containment and recovery equipment has been designed to be simple and portable albeit durable and effective to use. The containerized response tools are available for any type of shoreline.



### Industrial Applications

The range of Lamor industrial solutions facilitate optimal oil recovery, fire hazard reduction and minimize aggressive release of odors as well as hydrocarbon emissions.



### Land Remediation Applications

Lamor's land remediation solutions are designed for operations in deserts, swamps and marshes, as well as for areas with industrial pollution. Lamor also develops turnkey solutions for hazardous materials.

# 1 | LAMOR SKIMMER SYSTEM-SMALL

Lamor skimmer systems small are designed for multiple usages and scenarios.  
 PORTABLE | SMALL SIZE | MULTIPLE CAPACITIES | EASY TO USE

## Lamor Minimax (LMM) 12

The LMM 12 is a light, portable suction-type oil skimmer, designed to recover oil from shorelines, harbors, rivers and lakes. The LMM 12 uses the well proven Lamor brush wheel system, which combines high oil recovery capacity with a low free water pick-up rate. The LMM 12 has proven its efficiency in continuous recovery operations in hundreds of oil spills, in all con-

ditions and varying types of spilled oil. Moreover, its capacity is certified by Bureau Veritas.

The LMM 12, weighing only 28 kg, is a hand portable skimmer with a recovery rate of up to 19.6 m<sup>3</sup>/hr (ASTM F 631-99). The certified maximum capacity in ideal conditions is 45.4 m<sup>3</sup>/hr. The brush wheels will recover any floating oils which remain fluid.

The LMM 12 is entirely hydraulic and is supplied complete with a diesel powered hydraulic power pack and all necessary ancillary equipment. The unit should be connected to an effective suction pump or vacuum system. Optionally the power pack can be operated by electricity, gasoline or diesel.



### Technical Specifications

Length, mm	840
Width, mm	665
Height, mm	370
Weight, kg	28
Draft, mm	120
Certified capacity, m <sup>3</sup> /h	45,4*
Free water collected, %	<5
Hydraulic flow (skimmer only), l/min	1-3
Hydraulic pressure, bar	60-100
Power requirement, kw	0.3

\*Capacity related to pump selection

### Preferred package solution



### Preferred usage areas

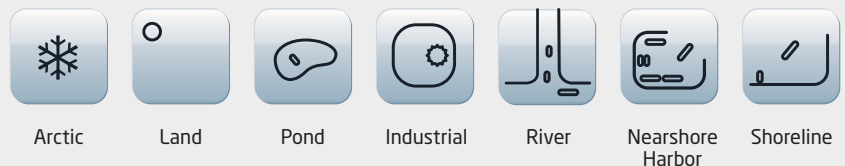



# Lamor Rock Cleaner (LRC)

The LRC is designed for oil recovery operations on rocky shorelines, in harbors, at oil terminals etc. It has an adjustable handle and can be carried with a harness in a comfortable ergonomic position. The LRC is an important tool in the Lamor beach cleaning concept and its recovery capacity in varying oil viscosities has been certified by

Bureau Veritas.

Compared to conventional methods, the LRC offers new possibilities thanks to the Lamor stiff-brush technology combined with its small size, making it possible to recover oil from the water as well as from land, concrete, asphalt, oil booms, etc.

It is recommended to use the LRC

with a Lamor Stone Catcher to protect the suction pump in use. The LRC can be connected to many different power sources, vacuum pumps or to a vacuum truck. The LRC can also be used for varying chemical clean-up operations since it is made in stainless steel and aluminum.



## Technical Specifications

Length, mm	1500
Width, mm	400
Weight, kg	6.5
Certified capacity, m <sup>3</sup> /h	9.7*
Free water collected, %	<5
Hydraulic flow (skimmer only), l/min	1-3
Hydraulic pressure, bar	60-100
Power requirement, kW	0.3

\*Capacity related to pump selection

## Preferred package solution

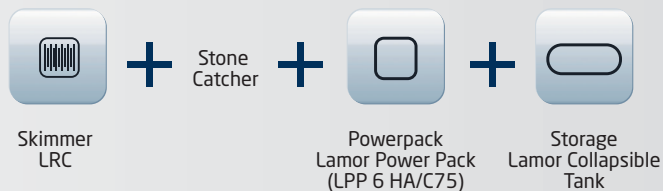

## Preferred usage areas

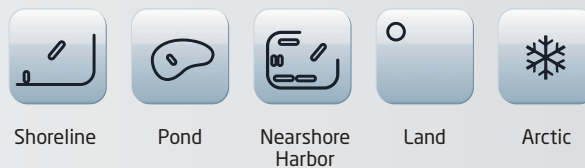

## LAMOR SKIMMER SYSTEM-SMALL

Lamor skimmer systems small are designed for multiple usages and scenarios.  
PORTABLE | SMALL SIZE | MULTIPLE CAPACITIES | EASY TO USE

# Lamor Weir Skimmers (LWS) 500/800

**The light-weight and self-adjusting LWS** provide the operator with precise control of the skimming process and offers a high recovery capacity in all operating conditions.

The LWS's large-diameter, free-floating weir has the ability to follow

choppy waves. Coupled with its high buoyancy-to-weight ratio and low inertial mass, this gives this new generation of weir skimmer excellent sea-keeping characteristics.

The LWS is designed to provide many years of reliable service and the

hopper and float arms are manufactured using marine grade aluminum and stainless steel with three uniquely and specially designed polyethylene floats and a single central lifting point.





**Technical Specifications**

LWS	500	800
Length, mm	2200	2540
Width, mm	2300	2530
Height, mm	790	850
Diameter weir, mm	500	800
Weight, kg	54	73
Certified capacity, m <sup>3</sup> /h	70*	112*
Free water content	<30%	<30%

\*Capacity related to pump selection

**Preferred package solution**



**Preferred usage areas**



## LAMOR SKIMMER SYSTEM-SMALL

Lamor skimmer systems small are designed for multiple usages and scenarios.  
PORTABLE | SMALL SIZE | MULTIPLE CAPACITIES | EASY TO USE

# Lamor Brush Adapter (LBA)

## for Weir Skimmers (LWS) 500/800

The LBA (patent pending) is a brush-type oil recovery module designed to fit quickly and easily onto the hopper of a weir skimmer. The purpose of the device is to improve the overall recovery efficiency, i.e. reduce free water recovered with oil, and to improve the performance in very high viscosity oils.

The LBA has four banks of brush wheels, which rotate downward into the oil layer creating a strong inflow. Oil recovery capacities of the brush adapters in 25 mm thick layer of medium oil viscosity exceed 240 m<sup>2</sup>/hr and are certified by Bureau Veritas.

The LBA brush banks are mounted

within a sturdy aluminum frame with a center-lifting eye. The brushes are driven by two hydraulic motors, which are powered by a single hydraulic circuit.

The technical specifications for a brush adaptor suited for the LWS 800 are as follows:



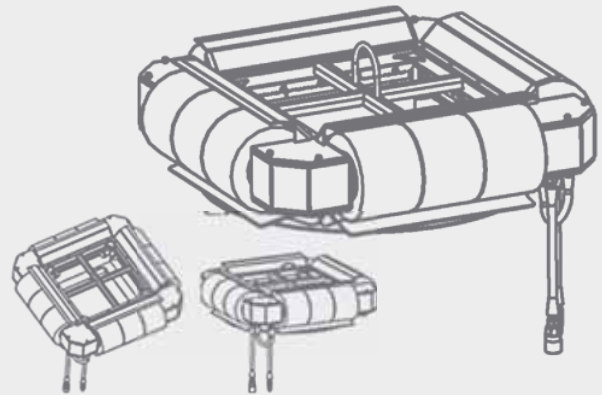

### Technical Specifications

LBA	500	800
Length, mm	800	970
Width, mm	800	970
Height, mm	420	420
Weight, kg	46	60
Certified capacity, m <sup>3</sup> /h	180	240*
Free water collected, %	<5	<5
Hydraulic flow (skimmer only), l/min	8	8
Hydraulic pressure, bar	170	170
Power requirement, kW	2.2	2.2

\*Capacity related to pump selection

### Preferred package solution

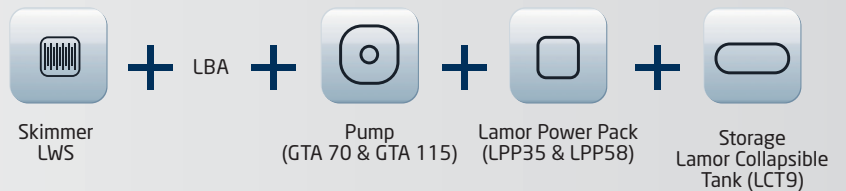

### Preferred usage areas



## LAMOR SKIMMER SYSTEMS-MEDIUM

Lamor skimmer systems-medium are designed for multiple usages and scenarios.  
STIFF BRUSH TECHNOLOGY | DURABLE | LOW MAINTENANCE | EASY TO USE

# Lamor Minimax (LMM) 30

The **LMM 30** is a stiff-brush conveyor belt-type oil skimmer designed to recover oil and contaminated debris in fast flowing rivers, oil ponds, harbors or as an advancing side sweep skimmer. Surface water, oil and debris are drawn into the skimmer with a water suction propeller forcing oil to the brush system.

The brush conveyor recovers all oil types but is particularly effective on weathered oils, crude, high viscosity bunker oil, emulsions, and high concentrations of oily debris, while collecting almost no free water. Oil and oily debris are separated, lifted, and delivered into a debris basket and collection sump. This skimmer has a recovery efficiency of 95%.

efficiency of 95%.

The patented V-Brush belt combines high oil recovery capacity with low free water pick-up. It has an oil recovery rate of 30m<sup>3</sup>/hr. That said, capacity tests, conducted by Bureau Veritas, certified a recovery rate of 53.1m<sup>3</sup>/h.



### Technical Specifications

Length, mm	2400
Width, mm	1720
Height, mm	1400
Weight, kg	180
Weight, with pump, kg	230*
Certified capacity, m <sup>3</sup> /h	53.1*
Free water content	<5%
Hydraulic flow (skimmer only), l/min	10-15
Hydraulic pressure, bar	60-150
Power requirement, kW	4

\* Related to pump selection

### Preferred package solution



### Preferred usage areas



# Lamor Multimax (LAM) 50

The **LAM 50** is a stiff-brush conveyor belt-type oil skimmer designed to recover oil in fast flowing rivers, oil ponds, harbors or as an advancing side sweep skimmer. The conveyor belt consists of three stiff-brush-chains. The brush conveyor can be rotated in both directions and in addition to the patented double-action brush cleaner, it can be used in several operational

modes to comply with stationary or advancing skimming in all oil types from light to extremely heavy viscous oils.

The oleophilic brush conveyor belt separates the oil from the water and lifts it to the specially designed brush cleaner from where the oil is directed to the oil transfer pump. The brush conveyor also brings up ice and debris

mixed in the oil to the collection hopper. The collection hopper can also be supplied with heating for Arctic conditions.

During certified capacity tests, conducted by Bureau Veritas, a recovery rate of 51.2 m<sup>3</sup>/h was achieved.



## Technical Specifications

Length, mm	1215
Width, mm	1335
Height, mm	1100
Weight, kg	122
Weight with pump, kg	170*
Certified capacity, m <sup>3</sup> /h	51.2*
Free water content	<5%
Hydraulic flow (skimmer only), l/min	10-15
Hydraulic pressure, bar	60-150
Power requirement max, kW	4

\* Related to pump selection

## Preferred package solution



## Preferred usage areas

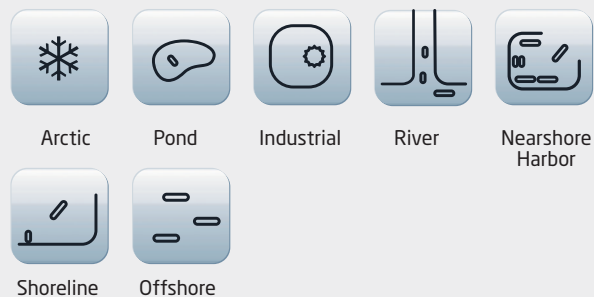

## LAMOR SKIMMER SYSTEMS-MEDIUM/LARGE

Lamor skimmer systems-medium are designed for multiple usages and scenarios.  
STIFF BRUSH TECHNOLOGY | DURABLE | LOW MAINTENANCE | EASY TO USE

# Lamor Multi Skimmer (LMS)

The LMS is a flexible high capacity free-floating skimmer, which is designed with interchangeable brush, disc, and drum modules in a triangular configuration. The LMS can be equipped with three individual skimmer units or with a combination of all three.

The LMS works equally well for

near shore, shallow water skimming as well as for open sea operations. Surface water and oil are drawn into the skimmer by the downward rotation of the skimming devices so oil adheres to the oleophilic surfaces, is separated and scraped into the collection sump.

The LMS recovery modules offer

optimum efficiency in all oil types, including diesel, fresh crude, high viscosity bunker oil and emulsions, and collect virtually no free water. The brush modules are offered as standard since they offer the highest recovery capacity over the widest range of oils.

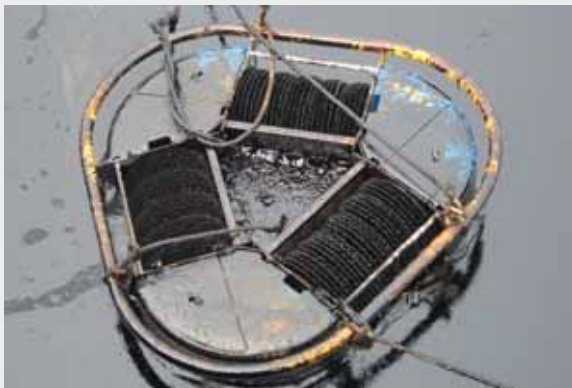

### Technical Specifications

Length, mm	1565
Width, mm	1645
Height, mm	1224
Weight, kg	150
Weight with pump, kg	199*
Draft, mm	500
Capacity, certified ASTM, m <sup>3</sup> /h	150,6*
Free water collected	<5%
Hydraulic flow (skimmer only), l/min	5
Hydraulic pressure, bar	70-150
Power requirement, kW	0.6-2.5

\* Related to pump selection

### Preferred package solution



### Preferred usage areas





## LAMOR SKIMMER SYSTEMS-LARGE

Lamor large skimmer systems are designed for multiple usages and scenarios.  
VESSEL MOUNTED | FREE FLOATING | REMOTE CONTROLLED | LOW MAINTENANCE | EASY TO USE

# Lamor Oil Recovery Bucket (LRB)

The **LRB** can be effectively operated by a crane on board a vessel or excavator. It is a practical piece of equipment for pit cleaning and oil spills on land, shorelines, swamp areas or icy waters.

The LRB is based on the proven Lamor stiff-brush wheel technology and it offers the highest possible performance and safety levels in oil spill recovery operations. It combines the efficient cleaning of the Lamor Brush

Wheel enhanced by the proven pumping performance of an optional positive displacement Lamor Archimedes screw type pump.

The skimmer brush can be operated in both directions depending of the oil type. The LRB system is unaffected by the floating debris normally found in an oil slick.

The skimmer automatically separates oils, emulsions and oily debris

from sea water or soils. Recovered oil normally contains less than 5% free water.

The skimmer is ideal for oil recovery in ice operated e.g. from a vessel crane. The skimmer is typically operated via a remote control.



LRB 150



LRB 250

### Technical Specifications

LRB	40	150	250
Length, mm	880	1800	2796
Width, mm	680	1500	2360
Height, mm	800	1200	1320
Weight, kg	75	900	1600
Certified capacity, m <sup>3</sup> /h	19*	115*	140*
Free water content	<5%	<5%	<5%
Hydraulic flow (skimmer only), l/min	20	30	30
Hydraulic pressure, bar	180	210	210
Power requirement, kW	10	15	15

\*Capacity related to pump selection



LRB 40

## LAMOR SKIMMER SYSTEMS-LARGE

Lamor large skimmer systems are designed for multiple usages and scenarios.  
VESSEL MOUNTED | FREE FLOATING | REMOTE CONTROLLED | LOW MAINTENANCE | EASY TO USE

# Lamor Arctic Skimmer (LAS)

The LAS is a special purpose oil recovery system designed for operation in extreme cold and ice conditions. The LAS is normally deployed by a crane or davit but can be also used as free floating skimmer utilizing the optional floats when required.

The LAS incorporates static ice deflection pipes and rotating brush

wheels for oil separation and collection. The two brush wheels collect and separate the oil from the water, any encountered ice pieces are crushed by the ice crushing screws inside the hopper and these screws also feed the oil to the efficient built-in Lamor GT A Positive Displacement Archimedes Screw type oil transfer pump.

The LAS is equipped with a warm water injection system to improve recovery in Arctic conditions.

The LAS represents a technical breakthrough in the development of equipment that provides an efficient and practical solution to recovery in Arctic conditions.



### Technical Specifications

Length, mm	1850
Width, mm	1414
Height, mm	2182
Weight, kg	870
Weight with pump, kg	950*
Certified capacity, m <sup>3</sup> /h	125*
Free water content	<5%
Hydraulic pressure, bar	150-200
Power requirement, kW	20-30

\* Related to pump selection

### Preferred package solution



### Preferred usage areas

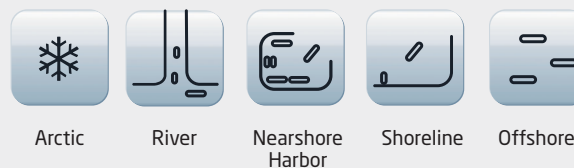

# Lamor Bow Collector (LBC)

The LBC is a stiff brush conveyor belt unit which effectively recovers oil and debris. The LBC operates most effectively at vessel speeds of up to four knots. Forward motion of the vessel concentrates surface oil and oily debris into the brush conveyor for separation and recovery.

The LBC collects oils of all types and viscosities and can operate in choppy sea conditions without disrupted performance and its brush con-

veyor automatically separates and recovers oils, emulsions and oily debris from the water and delivers it to deck level. Recovered oil contains less than 5% free water.

The brush can be either brush chain or brush belt. The number of brushes varies from 2-6. Also length of brush conveyor varies pending the desired capacity and the size of the vessel. The skimmer module is hydraulically powered and off-loaded by a

suction pump, Archimedes screw pump, a centrifugal pump or as direct flow into a basin/tank. The system can be supplied with portable power packs and can also be operated using vessel hydraulics. The skimmer has a tilt cylinder for changing between storage and operational positions.

The technical specifications vary on the size of the LBC and vessel.



## Technical Specifications

LBC	2C/3000	6B/3750
Length, mm	3000	3750
Width, mm	400	1010
Sweeping width, mm	3300	3480
Weight, kg	280	310
Certified capacity, m <sup>3</sup> /h	101*	203*
Free water content	<5%	<5%
Hydraulic flow, l/min	10-15	10-15
Hydraulic pressure, bar	150	150
Power requirement, kW	3-5	3-5

\*Capacity related to pump selection

## Preferred package solution



## Preferred usage areas

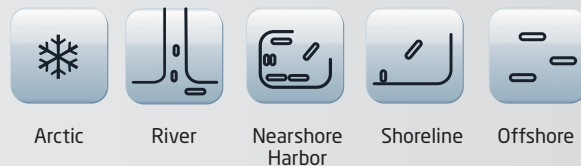

## LAMOR SKIMMER SYSTEMS-LARGE

Lamor large skimmer systems are designed for multiple usages and scenarios.  
VESSEL MOUNTED | FREE FLOATING | REMOTE CONTROLLED | LOW MAINTENANCE | EASY TO USE

# Lamor Free Floating Skimmer (LFF) 100

The **LFF100** is a very high capacity free-floating skimmer designed for open ocean oil recovery operations. The LFF100 is fitted with two V-chain pocket brush type conveyors for efficient collection of all types of floating oil from light to viscous oils and emulsions. Each brush chain conveyor consists of four brush chains.

The new generation Brush Conveyor Belt is a double acting skimming system for the LFF100. The double acting brush conveyor belt can be rotated in both directions and has a double brush scraper that allows the two-way operation for all oils. Also to enhance the selectivity to separate oils, the unit has an adjustable back plate to control the flow when recovering light, medium or heavy viscous oils.

The new skimmer design processes the oil on the water surface to the brush system for recovery. The brush conveyor system has two lengths of bristles, which by creating pockets to the conveyor belt recovers all kinds of oils also when large amounts of floating debris is present. The skimmer can operate in adverse weather and sea conditions without losing performance and collects less than 5 % free water making maximum use of valuable storage volume.

Recovered oil is offloaded by a high volume Lamor GTA pump with capacity of 115 or 140 m<sup>3</sup>/hr with more than 500.000 cSt oil. Tested and certified skimming capacity for 1 million cSt bitumen is 102,6 m<sup>3</sup>/h and for IFO 40 intermediate fuel oil 111 m<sup>3</sup>/h.

The skimmer is hydraulically operated and fitted with two thrusters to allow

the operator to maneuver the skimmer to where the oil is most heavily concentrated. The skimmer is typically radio remote controlled (both EX and non-EX).

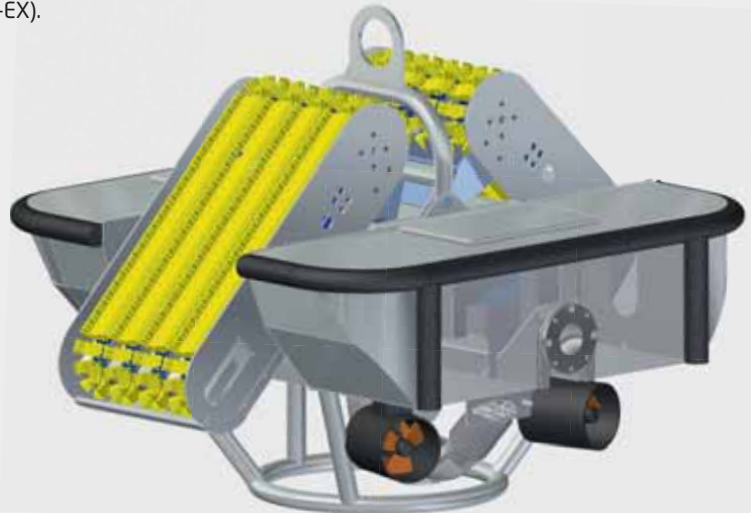



### Technical Specifications

Length, mm	2290
Width, mm	2250
Height, mm	1946
Weight, kg	850
Weight with pump, kg	920*
Certified capacity, m <sup>3</sup> /h	405*
Free water content	<5%
Hydraulic flow (skimmer only), l/min	40-60
Hydraulic pressure, bar	210
Hydraulic thrusters, kW	2 x 13.5
Power requirement, kW	30

\* Related to pump selection

### Preferred package solution

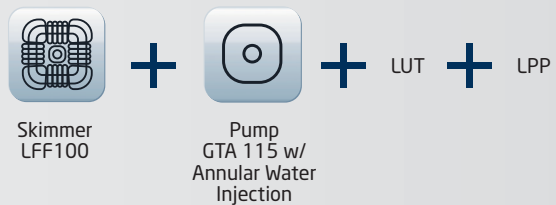

### Preferred usage areas



## LAMOR SKIMMER SYSTEMS-LARGE

Lamor large skimmer systems are designed for multiple usages and scenarios.  
VESSEL MOUNTED | FREE FLOATING | REMOTE CONTROLLED | LOW MAINTENANCE | EASY TO USE

# Lamor Weir Skimmer (LWS) 1300

**The free-floating offshore LWS 1300** is a high capacity weir skimmer designed for open ocean oil recovery operations. It is equipped with a fully automatic floating weir to separate and collect the oil into the hopper. The self-adjusting weir gives the operator precise control of the skimming process and offers a high recovery capacity in all operating conditions. The skimmer can be fitted with different kinds of off-loading pumps to enhance the recovery capacity all depending on the viscosity of the recovered oil. The skimmer head is designed to enable

easy and swift change between the MSP 150 centrifugal screw pump and the GT A 115 positive displacement Archimedes screw pump.

The MSP 150 oil transfer pump is a high capacity unit that has been designed for efficient handling of viscous liquids, bulky solids and shear-sensitive liquids. The Lamor MSP 150 centrifugal screw pump is driven by an axial hydraulic motor and provides not only a powerful suction but also high discharge pressure. It is suitable for operations in hazardous areas.

The skimmer is hydraulically operated and fitted with two thrusters to allow the operator to maneuver the skimmer to where oil is most heavily concentrated. The radio-remote control can be operated from up to 200 m distance from the skimmer.



LWS1300 with  
Brush Adaptor



### Technical Specifications

LWS (w / brush adaptor)	1300
Length, mm	2650
Width, mm	2215
Height, mm	1830
Weight, kg	240
Weight (incl. brush adaptor and pump), kg	720
Certified capacity, m <sup>3</sup> /h	360*
Hydraulic thrusters, kW	2x13,5
Hydraulic flow, l/min	35
Hydraulic pressure, bar	210
Power requirement, kW	13

\*Capacity related to pump selection

### Preferred package solution

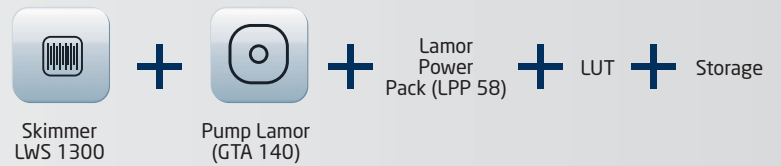

### Preferred usage areas

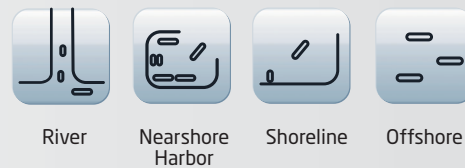

## LAMOR SKIMMER SYSTEMS-LARGE

Lamor large skimmer systems are designed for multiple usages and scenarios.  
VESSEL MOUNTED | FREE FLOATING | REMOTE CONTROLLED | LOW MAINTENANCE | EASY TO USE

# Lamor Side Collector (LSC)

The LSC is a vessel side mounted advancing skimming system for tug and work boats as well as for large vessels. In addition to the skimmer unit on one or two sides of the work boat, the total LSC system typically consists of automatic or manual outrigger jib arms and sweeping booms.

The LSC system is based upon the proven stiff brush technology. It offers high performance and safety for near- and offshore oil spill recovery. The LSC operates effectively at vessel speeds of up to four knots, resulting in excellent vessel maneuverability and very high oil encounter rate.

The new generation brush conveyor belt is a double acting skimming system for the LSC. The double acting

brush conveyor belt can be rotated in both directions and has a double brush scraper that allows the two-way operation for all kinds of oils from light to the heaviest. Moreover, to enhance the selectivity to separate oils, the unit has an adjustable back plate to control the flow when recovering light, medium or heavy viscous oils.

The encountered oil is directed to the skimmer and scraped further to the incorporated oil transfer pump. The number of brush chains selected is based on vessel size and required capacity.

Owing to the high recovery speed, the system is able to recover the largest possible area of an expanding oil slick at sea. The deployment of the

system can start skimming oil within minutes of arrival on site and be operated by a small crew requiring very little specialized training.

Detailed drawings and design of the system are tailor-made for each individual vessel for optimized efficiency, operation and safety, taking into account vessel particulars, capacity requirements and other factors.

The LSC system can be fitted in various types and sizes of vessels allowing them to serve as oil recovery units. It can be installed in new-buildings as well as in existing vessels. Please note the specifications shown here are examples for a single side system.

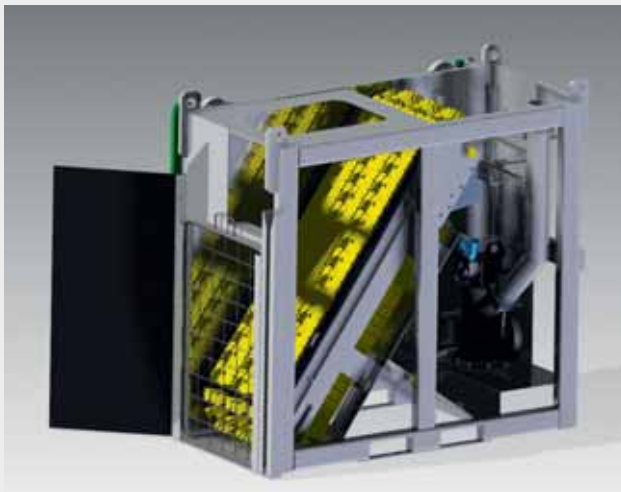

### Technical Specifications

A few examples of Lamor's product range.

LSC	3C	5C
Length, mm	1700 / 2370	3000-3500
Width, mm	930 / 880	ca. 1400
Height, mm	1590 / 2155	2800-3500
Weight, kg	365 / 550	1000
Certified capacity, m <sup>3</sup> /h	152*	255*
Free water content	<5%	<5%
Recovery speed	1-4 knots	1-4 knots
Hydraulic flow (skimmer only), l/min	20-40	20-40
Hydraulic pressure, bar	210	210
Power requirement, kW	10	10

\*Capacity related to pump selection





Preferred package solution

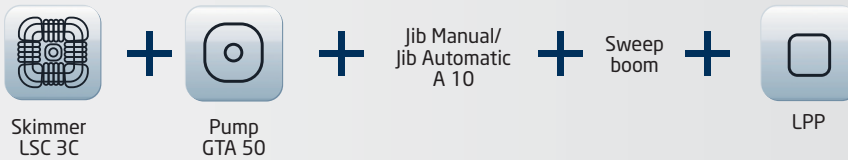

Preferred usage areas

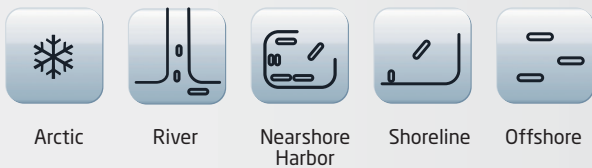

Example Scope of Supply

- LSC
- Frame
- Winch
- GT A Pump
- Hydraulic hoses
- Oil transfer hoses
- Jib rigging arm (manual/automatic)
- Sweep boom (foam/air filled)
- Sweep boom winder
- Lamor power-pack (depending on LSC/pump)
- Flat
- (Air blower)
- Accessories

## LAMOR SKIMMER SYSTEMS-LARGE

Lamor large skimmer systems are designed for multiple usages and scenarios.  
VESSEL MOUNTED | FREE FLOATING | REMOTE CONTROLLED | LOW MAINTENANCE | EASY TO USE

# Lamor Built-In Oil Recovery System (LORS)

**The LORS** is a vessel mounted advancing skimming system. The system is suitable for medium size work boats and tugs with lengths varying from approx. 15 - 35 m as well as for large vessels ranging from 30 - 100 m. In addition to the skimming unit, the total LORS system typically consists of fixed or telescopic outrigger jib arms, sweeping booms with or without boom winder, oil transfer pump and control panel with or without radio remote control.

More than 1000 vessels around the world are equipped with Lamor

advancing skimming systems. About 500 of these have been equipped with LORS systems. Most of the latest deliveries are fully hydraulic operated systems so no manual assembly and disassembly is required making deployment and retrieval faster and safer.

Deployment of the LORS makes the entire vessel an "oil slick processing system". The patented LORS uses the vessel's forward motion to deflect surface water and oil from the collection area, formed by the jib arm and sweep boom, into the recovery process. The flow of water carries oil through the recovery channel, where the oil is ef-

ficiently separated and removed from the flow with the brush skimmer.

The new generation Brush Conveyor Belt is a double acting skimming system for the LORS. The double acting brush conveyor belt can be rotated in both directions and has a double brush scraper that allows the two-way operation for all kinds of oils from light to the heaviest. Also to enhance the selectivity to separate oils, the unit has an adjustable back plate to control the flow when recovering light, medium or heavy viscous oils.

The rotating brushes collect oils of all types, including weathered bunker oil and emulsions, with very little water, making efficient use of on-board tankage. The brush skimmer system is unaffected by the type of floating debris normally found in an oil slick. The number of brush rows can be selected based on vessel size, operating condition and required capacity. Typically systems have between 2-6 rows, up to 10-row systems per side have been made.

The LORS system can be deployed and operated by a small crew very quickly. Simple and intuitive operation requires very little specialized training. When the system is not in use, it is stored below deck and is otherwise independent of the other functions of the vessel.

Please note the technical specifications show dimensions and figures for a single side system only, and are just examples of a wide range of LORS.

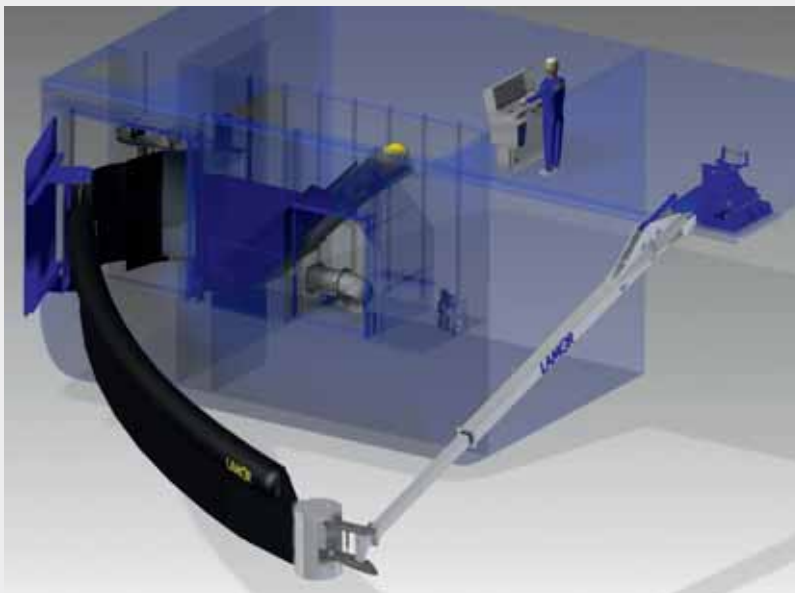



### Technical Specifications

A few examples of Lamor's product range.

LORS	4C	5C
Length, mm	2500-4500	3500-5000
Width, mm	1000	1500
Height, mm	2000	2000-3000
Weight, system kg	2500	3000
Power requirement (skimmer only), kW	10	10
Certified capacity, m <sup>3</sup> /h	203*	260*
Free water content	<5%	<5%
Recovery speed	1 - 4 knots	1 - 4 knots
Hydraulic flow (skimmer only), l/min	20-40	20-40
Hydraulic pressure, bar	210	210

\*Capacity related to pump selection

### Features & Benefits

- Safe, fast and easy deployment
- Operating speed up to 4 knots
- Very high oil encounter rate
- High recovery efficiency in all conditions
- <5% free water collected
- Effective in choppy waves without collecting excessive amounts of water
- Recovery of all types of oils up to the highest viscous oils and emulsions
- Excellent ice, debris and seaweed handling capability
- Simple and reliable operation

### Example Scope of Supply (one side)

- Brush skimmer
- Flow plate and rollers
- Flow propeller
- Sweep boom with end float (foam or air filled)
- Sweep boom winder
- Jib rigging arm (manual / fixed hydraulic / telescopic)
- Control panel
- Radio remote control, Ea ZONE1 if required
- Oil transfer pump
- Accessories (front rope, air blower etc.)
- Design

## LAMOR SKIMMER SYSTEMS-LARGE

Lamor large skimmer systems are designed for multiple usages and scenarios.  
VESSEL MOUNTED | FREE FLOATING | REMOTE CONTROLLED | LOW MAINTENANCE | EASY TO USE

# Lamor Stiff Sweep Arm (LSS) 12 m/15 m

The LSS incorporates the proven stiff brush oil recovery technology and also optionally the weir skimmer as exchangeable modules. The design offers high performance and safety for off-shore oil spill recovery operations.

With the LSS deployed, the entire vessel becomes an "oil slick processing system". The forward motion of the vessel deflects surface water and oil

from the collection area formed by the sweeping arm into the recovery process in the apex formed by the sweeping arm and vessel hull. The flow leads the oil to the collection module which is equipped either by a Lamor 6 chain brush skimmer or a weir type skimmer and the oil transfer pump.

The advantage of the brush assisted stiff sweep system is that the

brush conveyor effectively separates the oil from the free flow water. The water content in recovered oil is less than 5%.

The conveyor belt is mounted in the apex of the Lamor Stiff Sweep. When the system is not in use it is stored on-deck allowing the vessel to be utilized for multiple other uses.





### Technical specifications

LSS	12 m	15 m
Length, mm	11860	15350
Width, mm	3232	3600
Height, mm	2120	2120
Weight, kg	4335	5390
Skimmer	6c	6c
Hydraulic flow (skimmer only), l/min	20	20
Hydraulic pressure, bar	210	210
Power requirement, kW	7	7
Free water content, %	<5	<5

### Features & Benefits

- Robust design. Fast Deployment.
- Less than 5% free water content in collected oil with brush skimmer module.
- Suitable for efficient collection of all types of oil.

### Example Scope of Supply:

- LSS
- Skimmer module
- GT A pump
- Hydraulic hoses
- Oil transfer hoses
- LPP power-pack (depending on pump)
- Accessories
- Dedicated two-point lifting crane.

# Lamor Umbilical Hose Reel (LUT) with Telescopic Crane Arm

**Instead of using a separate crane** for skimmer deployment, the LUT can be equipped with a telescopic crane arm that can be operated by one person. The telescopic crane arm is built in accordance with NOFO standards that enable deployment even from below deck through the side hatch.

The oil transfer and hydraulic hoses

are connected to a manifold at the hub of the reel with pump-through swivel joints to allow the hoses to be energized continuously and at any deployed length.

The LUT is powered by a hydraulic motor with hydraulically released brake. As an option, the reel can be furnished according to requirements of EX proof

certificate for Zone I. The swivel has gone through EX testing at the Technical Research Center (VTT) in Finland during a four week period in + 90°C, humidity 90 % and another test in -40 °C for 2 days.

Oil transfer and hydraulic hoses can be supplied in various lengths.





### Technical Specifications

Length, mm	6057
Width, mm	2700
Height, mm	3465
Light weight, kg	12100
Capacity, m	90
Load at standard reach, kg	1900
Standard reach, m	16.5
Lifting capacity at 40 deg.	3 tons
Rotation	360 deg
Rotation torque, kNm	40
Hydraulic flow, l/min	40
Hydraulic pressure, bar	350



## LAMOR OIL BOOM SYSTEM

Lamor oil booms come in various sizes and materials pending usage and scenario.  
 SUPPLIED ON REELS OR RACKS | UV RESISTANT | POLYESTER, VULCANIZED RUBBER, ETC.  
 | RE-USABLE WITH LAMOR BOOM WASHER | FAST AND EASY DEPLOYMENT

# Lamor Auto Booms (LAB)

**The unique design of** the LAB makes it possible to store up to 600m on one compact storage reel. As the boom is deployed from the reel it is automatically inflated from a single air source attached to the end of the boom. Upon inflation the patented internal design automatically separates the floatation chambers.

Each individual buoyancy chamber is isolated. In the event that one air chamber may become damaged or deflated, adjacent chambers will not be affected and will remain inflated. A layer of closed cell foam provides additional floatation for positive reserve buoyancy on each chamber.



### Auto Booms

Product	Section (m)	Flat Height (mm)	Weight (kg/m)	Freeboard (mm)	Draft (mm)	Ballast (kg/m)
Harbor Model	30	800	3.8	305	460	2.5
Offshore Model	30	1090	6	460	640	3.6
Deep Sea Model	30	1630	6.8	610	910	3.6





### Technical Specifications

Section length, m	30
Freeboard, mm	305-610
Draft, mm	460-910
Total height, mm	800-1630
Weight (total operational), kg/m	3.8-6.8
Ballast weight, kg/m	2.5-3.6
Air chamber length, m	3.7
Coating	Urethane/Neoprene
Base fabric	Polyester
Inflation pressure, mbar	34

### Preferred package solution

LAB + Towing SET + Anchor SET + Air blower HAB200 + Boom Reel + LPP14

### Preferred usage areas

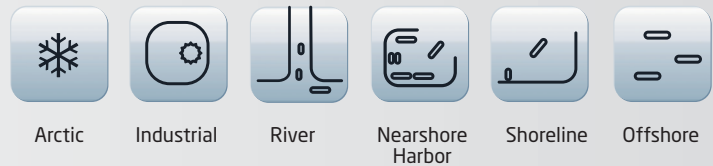

## LAMOR OIL BOOM SYSTEM

Lamor oil booms come in various sizes and materials pending usage and scenario.  
 SUPPLIED ON REELS OR RACKS | UV RESISTANT | POLYESTER, VULCANIZED RUBBER, ETC.  
 | RE-USABLE WITH LAMOR BOOM WASHER | FAST AND EASY DEPLOYMENT

# Lamor Foam Filled Oil Booms (FOB) 350-1500

The **FOB** is designed to provide a quick and dependable means of oil containment and it is fast to deploy, lightweight, robust and easy to handle. The FOB is well suited for emergency deployment or permanent use in harbors or oil terminals. It is available in sizes varying from 350-1500 mm in total height. The FOB is supplied in 25m sections but can be modified to different section lengths.

The FOB is manufactured using highly visible red PVC coated woven 1100 dtex polyester, which is resistant to the effects of oils and sunlight. Each section incorporates reflectors, supplemented by light pouches and built in chaff for radar detection. The floatation is derived from resilient closed cell foam and a ballast chain is incorporated into the skirt.

The FOB can be supplied in storage

racks, allowing sections to be pre-joined ready for rapid deployment or on powered reels holding up to 300m of boom for effortless deployment and recovery.

### Foam Filled Oil Booms

Product	Section (m)	Total Height (mm)	Operational Weight (kg/m)	Freeboard (mm)	Draft (mm)	Ballast (kg/m)
FOB 350/25m	25	350	3.5	150	200	1.9
FOB 500/25m	25	500	3.8	200	300	1.9
FOB 750/25m	25	750	4.2	250	500	1.9
FOB 900/25m	25	900	5.3	300	600	3
FOB 1000/25m	25	1000	5.7	350	650	3
FOB 1200/25m	25	1200	6.2	425	775	3
FOB 1500/25m	25	1500	7.5	500	1000	3



### Technical Specifications

Section length, m	25
Height, mm	350-1500
Weight (total operational), kg/m	3,5-7,5
Freeboard, mm	150-500
Draft, mm	200-1000
Ballast weight, kg/m	1,9-3
Temperature resistance	-35...+70 °C
Base fabric	1100 dtex polyester
Fabric Tensile strength	4000 N/5 cm

### Preferred package solution



### Preferred usage areas

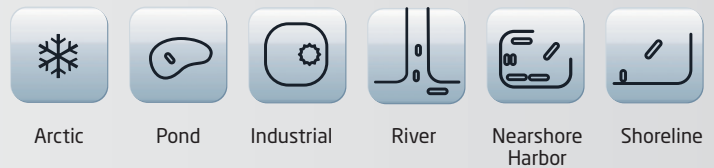

## LAMOR OIL BOOM SYSTEM

Lamor oil booms come in various sizes and materials pending usage and scenario.  
 SUPPLIED ON REELS OR RACKS | UV RESISTANT | POLYESTER, VULCANIZED RUBBER, ETC.  
 | RE-USABLE WITH LAMOR BOOM WASHER | FAST AND EASY DEPLOYMENT

# Lamor Inflatable Light Booms (ILB) 500-1200

The ILB is manufactured in high visibility orange PVC coated woven dtex 1100 polyester fabric which is resistant to oils and sunlight. The ILB is available in many different sizes ranging from 500-1200mm high and 25m lengths as standard. Other heights and section lengths are available on request.

There are four air chambers and four high quality Monsun XG 1" air valves in each section. A galvanized chain incorporated in the base of the skirt provides ballast. The ILB can be stored on powered winders with capacity for 250m boom enabling rapid deployment and recovery. Alternatively, short sections can be stored in boom

bags for easy access. The ILB can be easily deployed from the storage reel by only two operators, typically 250m in 10 - 15 minutes. The ILB boom is easy to clean after deployment with detergents, hot or cold pressure washers, or with the Lamor Boom Washing Machine.



### Inflatable Light Booms

Product	Section (m)	Operational Height (mm)	Weight (kg/m)	Freeboard (mm)	Draft (mm)	Ballast (kg/m)
ILB 500/25m	25	500	3	230	270	1
ILB 750/25m	25	750	3.5	300	450	1
ILB 1000/25m	25	1000	5.7	300	700	1
ILB 1200/25m	25	1200	6	400	800	1



### Technical Specifications

Section length, m	25
Height	500-1200
Weight (total operational), kg/m	3-6
Freeboard	230-400
Draft	270-800
Ballast weight, kg/m	1
Temperature resistance	-35...+70 °C
Base fabric	1100 dtex polyester
Fabric tensile strength	4000 N/5 cm
Air chamber length, m	4.85
Valve	Monsun G1"

### Preferred package solution

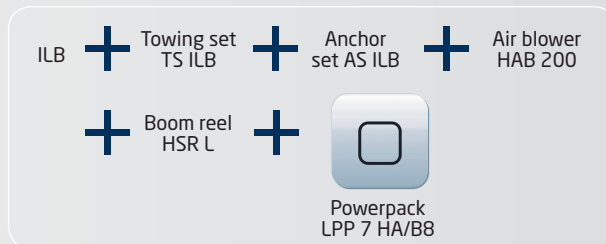

### Preferred usage areas

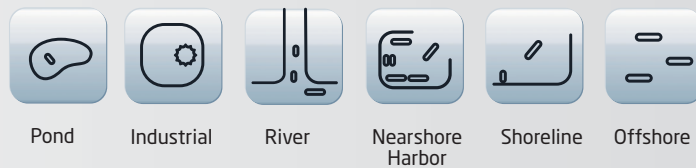

## LAMOR OIL BOOM SYSTEM

Lamor oil booms come in various sizes and materials pending usage and scenario.  
 SUPPLIED ON REELS OR RACKS | UV RESISTANT | POLYESTER, VULCANIZED RUBBER, ETC.  
 | RE-USABLE WITH LAMOR BOOM WASHER | FAST AND EASY DEPLOYMENT

# Lamor Heavy Duty Oil Booms (HDB) 900-2000

The HDB covers the increasing demand for a boom which is specifically suited for use in open seas, harbors and permanent installations such as oil terminals and power plants. The HDB is available in sizes varying from 900 to 2000mm in height and 50 or 100m section lengths.

The HDB is manufactured using the highest quality components and is

constructed so that two layers of synthetic fabric are vulcanized together with synthetic oil resistant rubber outer layers. The HDB is constructed using fully vulcanized and rubber welded parts without the use of any pop rivets. The synthetic coated outer layer gives the HDB excellent resistance to the affects of oil and UV degradation.

Inflation of the HDB is quick due to

the patented Lamor F1 air valve and use of a Lamor Air Blower. The complete use of the air valve at inflation can be carried out by one person. It is recommended the HDB be stored on a dedicated hydraulically powered reel, enabling deployment of up to 200 meters in approx. 15 minutes.

### The Heavy Duty Oil Booms

Product	Section (m)	Deflated Height (mm)	Weight (kg/m)	Freeboard (mm)	Draft (mm)	Buoyancy/weight ratio
HDB 900/50m	50	900	8.1	350	450	11:1
HDB 900/100m	100	900	8.1	350	450	11:1
HDB 1000/50m	50	1000	9.2	380	410	10.7:1
HDB 1000/100m	100	1000	9.2	380	410	10.7:1
HDB 1200/50m	50	1200	10.0	440	560	10:1
HDB 1200/100m	100	1200	10.0	440	560	10:1
HDB 1300/50m	50	1300	11.3	440	660	10:1
HDB 1300/100m	100	1300	11.3	440	660	10:1
HDB 1500/50m	50	1500	13.5	425	865	12:1
HDB 1500/100m	100	1500	13.5	425	865	12:1
HDB 1600/50m	50	1600	14.6	425	965	13.5:1
HDB 1600/100m	100	1600	14.6	425	965	13.5:1
HDB 1800/50m	50	1800	15.6	560	960	13:1
HDB 1800/100m	100	1800	15.6	560	960	13:1
HDB 2000/50m	50	2000	17.1	560	1160	12.5:1
HDB 2000/100m	100	2000	17.1	560	1160	12.5:1



### Technical Specifications

Section length, m	50 or 100
Height, mm	900-2000
Weight (total operational), kg/m	7,4-23,5
Freeboard, mm	350-560
Draft, mm	450-1160
Ballast weight, kg/m	1,5-4,5
Temperature resistance	-40...+60 °C
Base fabric	EP 315 and 400
Fabric Tensile strength	15750-20000 N/5 cm
Air chamber length, m	3
Air valve	F1

### Preferred package solution

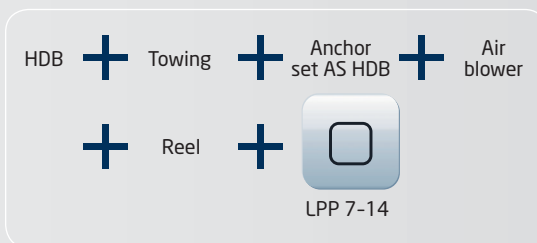

### Preferred usage areas



## LAMOR OIL BOOM SYSTEM

Lamor oil booms come in various sizes and materials pending usage and scenario.  
 SUPPLIED ON REELS OR RACKS | UV RESISTANT | POLYESTER, VULCANIZED RUBBER, ETC.  
 | RE-USABLE WITH LAMOR BOOM WASHER | FAST AND EASY DEPLOYMENT

# Lamor Solid Floatation Boom (SFB)

The SFB is developed to meet all current requirements for a rapid deployment coupled with financial sustainability. The SFB is a light-weight boom made of highly durable materials making it easy to deploy and designed to capture and contain floating oil and debris.

The SFB represents a cost-effective

way of maintaining readiness in multiple scenarios and environments ranging from industrial sites to rivers and harbors. Manufactured from PVC fabric with built in foam floatation, top tension cable, chain ballast and connectors, the versatile system is made in accordance with customer-specific needs.

The SFB is available in sizes ranging from 150 mm (6") to 635 mm (24") total height. The closed-cell foam logs are 1800 mm (6 ft) long. The most commonly ordered is the SFB 18", which has a section length of 30m, freeboard 150mm, draft 305mm, height 455mm, weight 3kg/m.



### Technical Specifications

Base fabric	Polyester
Fabric Tensile strength	2800 N/5 cm
Temperature resistance	-30 + 70 °C

### Preferred package solution

SFB 18" + Storage bag BSB

### Preferred usage areas



Arctic



River



Nearshore  
Harbor



Shoreline



Offshore



# Lamor Hydraulic Storage Reels (HSR) for Booms

The HSR is designed to store up foam filled oil boom (FOB), inflatable light oil boom (ILB) self-inflatable Lamor auto boom (LAB) or heavy duty oil booms.

The reels are driven by hydraulic motors, together with planetary reduction gear. They are operated by a hydraulic Lamor power-pack such as LPP 6, 7 or 14 kW, which allows easy deployment and recovery using minimal manpower.

The light weight reel frame is manufactured in steel and the spool in marine grade aluminum. The reel frame comprises fork lift channels and 4-point lifting points as standard for easy handling both on and offshore.

Marine twist locks and container corner guides can be fitted as desired. A canvas ensuring maximum protection for the stored boom is included.

## Technical Specifications A few examples of Lamor's product range.

BOOM REELS	HSR 1514	HSR 1817	HSR 1822	HSR 1830
Length, mm	2020	2400	2900	3654
Width, mm	1627	1800	1800	1800
Height, mm	1800	2100	2100	2100
Weight, kg	500	704	790	840
Reel diameter, mm	1500	1800	1800	1800
Reel inner width, mm	1400	1700	2200	3000
Reel material, spool	Aluminum	Aluminum	Aluminum	Aluminum
Frame material	Steel	Steel	Steel	Steel
Forklift channels	Yes	Yes	Yes	Yes
Hydraulic flow, l/min	15	15	15	15
Hydraulic pressure, bar	150-210	150-210	150-210	150-210



# Lamor Air Blowers

## Hydraulic Air Blower (HAB) 200

The HAB 200 is used for inflating booms. The air blower consists of a hydraulic motor and air blower installed in a portable aluminum frame.

The unit is supplied with hydraulic quick release TEMA couplings. The internals of the Lamor HAB 200 are protected by a suction filter. The Lamor HAB 200 has a set discharge pressure so the oil boom cannot be damaged during the inflation operation. Additionally the HAB 200 can be configured to provide suction for deflation of booms.

The Lamor HAB 200 can be powered by one of the family of Lamor hydraulic power packs or using vessel hydraulics.

## Lamor Diesel Driven Air Blower (DAB) 200

The DAB 200 is a belt driven radial fan. The diesel engine powered air blower DAB 200 is used for inflating booms. The air blower consists of a diesel engine and a hydraulic air blower.

The blower, the engine and impeller of sheet steel with backward curved blades are built in a casing of painted

steel. The internals of the Lamor DAB 200 are protected by a suction filter.

The DAB 200 has a set discharge pressure so the oil boom cannot be damaged during the inflation operation. Additionally the DAB 200 can be configured to provide suction for deflation of boom.

## Lamor Power Pack (LPP) 14 with Hydraulic Air Blower (HAB) 200

The LPP 14 with integrated HAB 200 is an ideal unit for deploying heavy duty oil booms from reels. There is a hydraulic outlet to operate the boom reel



DAB



LPP 14 with DAB

**Technical Specifications**  
A few examples of Lamor's product range.

when the HAB 200 is used for inflating booms.

The air intake of the HAB 200 air blower can be mechanically closed, when the air blower does not take any hydraulic power and both hydraulic outlets can be utilized to power other equipment.

The HAB 200 has a set discharge pressure so the oil boom cannot be damaged during the inflation operation.

The diesel engine, hydraulic pump and air blower are installed on a tough steel frame fitted with handle and wheels.

AIR BLOWERS	HAB 200	DAB 200	LPP 14 with HAB 200
Length, mm	550	1170	1200
Width, mmv	410	540	860
Height, mm	600	780	830
Weight, kg	40	85	256
Air flow, m <sup>3</sup> /h	400	400	400
Air pressure, bar	0.1	0.1	0.1
Hydraulic requirement, l/min	25-40	-	-
Hydraulic flow, l/min	25-40	-	20
Hydraulic pressure, bar	150	-	210
Hydraulic oil tank capacity, l			30
Engine power, kw	-	3.5	14
Fuel tank capacity, l	-	5	-



LPP 7 with HAB

# GT A Oil Transfer Pumps

GT A 20-30, GT A 50-70, GT A 115-140

**Lamor has developed** its own portfolio of oil transfer pumps, the GT A multi-purpose submersible Archimedes screw pumps with a capacity ranging from 20 to 140m<sup>3</sup>/h.

The design ensures a gentle pumping action that will not emulsify oily water, and ensures the efficient movement of material. In addition to being used as oil transfer pumps, the pumps

are well-suited to many applications such as offloading emergency pumping of heavy crude, bitumen, and for tank cleaning, pipeline maintenance etc.

The efficiency of the GT A pumps is increased thanks to a water/steam annular injection on the inlet as standard and a debris cutting knife to handle solids such as seaweed, plastics and ropes.

The pumps are constructed from robust seawater resistant aluminum for the casings and stainless, acid proof steel internals with special seals that ensure the pump remains "dry".

The pump range has been extensively tested in the field and is certified by Bureau Veritas for its recovery capacities in oils of varying viscosities.



## Features & Benefits

- Extreme viscous oil and debris handling capability
- Capacities from 20 to 140 m<sup>3</sup>/h (88 to 616 USGPM)
- High discharge pressure of 12 bar, even on water
- Total wear protection
- Simplified maintenance and repair

## Technical Specifications

Pump model	L (mm)	W (mm)	H (mm)	Weight (kg)	Capacity (m <sup>3</sup> /hr)	Discharge pressure (bar)	Hydraulic flow max. (l/min)	Hydraulic pressure max. (bar)
GT A 20	300	195	435	25	20	12	80	210
GT A 30	300	195	435	26	30	12	75	210
GT A 50	400	250	500	49	50	12	160	210
GT A 70	400	250	500	47	70	12	92	210
GT A 115	500	300	598	71	115	12	160	210
GT A 140	500	300	598	71	140	12	160	210

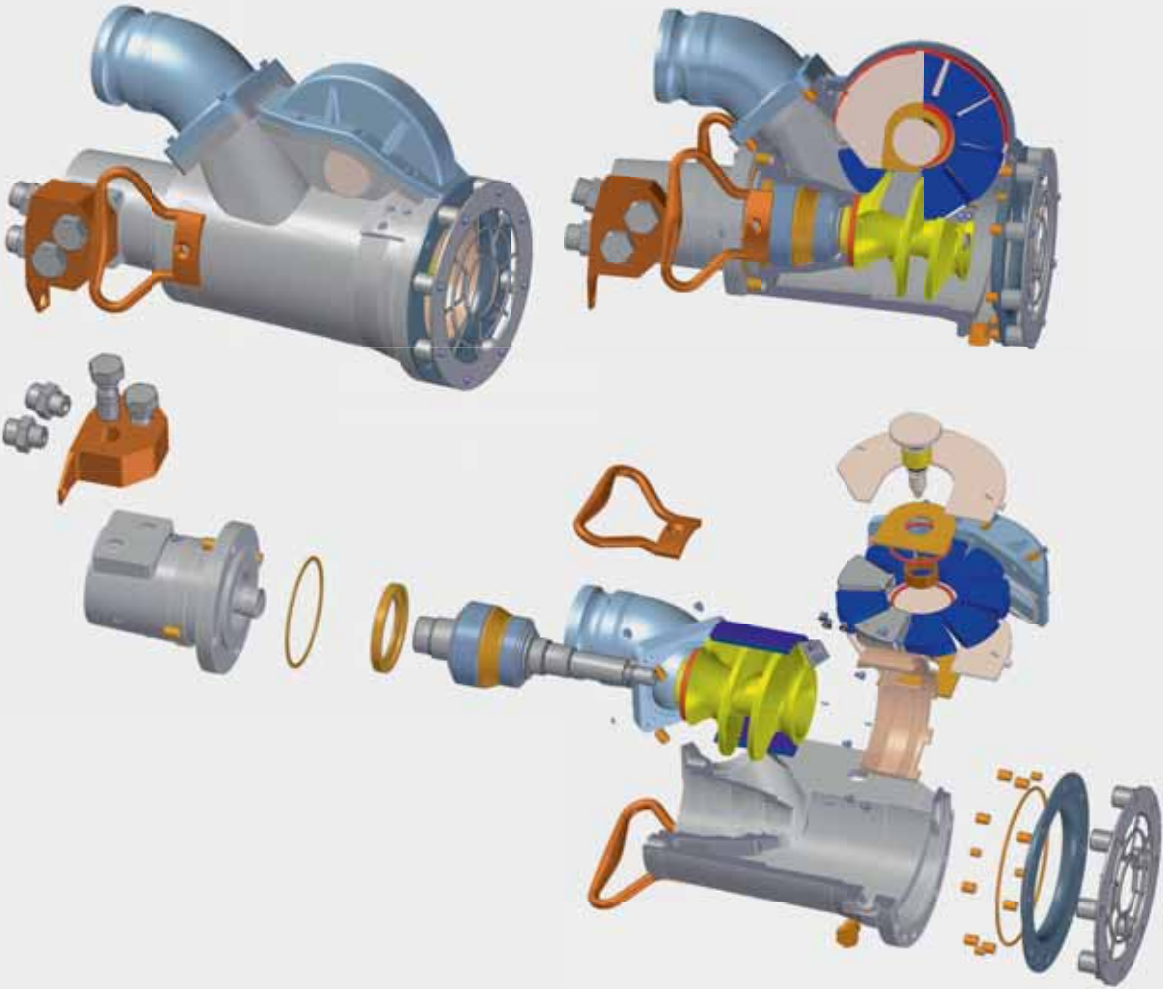

Preferred package solution

Pump GT A 20-30	+	Water injection LWI	+	Hose winder	+	Powerpack LPP 23D
Pump GT A 50	+	Water injection LWI	+	Hose winder LW/W 60/2 AI	+	Powerpack LPP 58D
Pump GT A 70	+	Water injection LWI	+	Hose winder LW/W 60/2 AI	+	Powerpack LPP 36D
Pump GT A 115-140	+	Water injection LWI	+	Hose winder LW/W 60/2 AI	+	Powerpack LPP 58D

Preferred usage areas

Arctic	Land	Pond	Industrial
River	Nearshore Harbor	Shoreline	Offshore

Lamor supplies a wide variety of portable and mobile power sources for effective and flexible operation of oil spill response equipment, such as skimmer systems, oil containment boom reels etc.

Depending on the scenario, the climate and recovery operations, numerous types of multi-purpose hydraulic, electric as well ex-proof electric power-packs can be supplied with various technical parameters, such as assembled powerful oil transfer pumps, Chalwyn valves, spark arrestors, container corners, stainless steel couplings, remote controls etc.

Power capacities vary from e.g. 3 kW to 200 kW. The engines are typically air cooled or turbocharged and charge water cooled, diesel engines. All power-packs are manufactured using high quality, durable components, guaranteeing a long service life and are backed by a worldwide service network with delivery of spare parts at short notice.

A selection of power-packs are presented here, the complete product range comprises several more models, options and custom-made solutions.

Due to stricter emission legislation worldwide, Lamor is developing a brand new product range of power-packs thus reducing the environmental footprints. The new ranges of power-packs will be remote controlled by using different modes enabling simultaneous utilization of a selection of various oil spill response equipment, such as skimmers, oil boom reels etc. Hence, one single power source is needed versus several different types of power-packs to supply power for various functions and OSR equipment. Moreover, the state-of-the-art power-packs have reduced noise emissions.

## POWER-PACKS WITH PUMP

# Lamor Hydraulic Power-pack (LPP) 6 HA and 7 HA with C75

The LPP 6 HA/C75 is a compact multi-purpose hydraulic power unit, coupled to a powerful transfer pump. Power is provided by a single cylinder air-cooled diesel engine generating 5.4 kW @ 3600 rpm.

The LPP 6 HA/C75 is equipped with electric start as standard and manual start as back-up. The LPP 6 HA can be equipped with spark arrestor and Chalwyn safety shut down valve.

The LPP6 HA/C75 comprises one hydraulic circuit capable of pumping 3 l/min at 150 bar, hydraulic flow is controlled by a valve located on the hydraulic pump body.

The LPP 6 HA/C75 provides ample power for operation of the Lamor range of skimmers. Moreover, the

LPP 6 HA/C75 can also be used to power the Lamor Light Boom Reel. The integral Spate C75 pump is a self-priming double diaphragm pump with a maximum capacity of 30 m<sup>3</sup>/h through 63.5 mm/2.5 inch (75 mm/3 inch option) inlet and discharge Camlock couplings. The Spate C75 can handle solids up to 6mm in size; all seals are constructed from synthetic rubber for protection against all oils encountered.

The LPP6 HA/C75 is mounted on a tough and portable steel double wheeled site chassis with collapsible handle allowing for easy deployment. If more capacity and power is required, while maintaining the same features and integral Spate C75 pump, the Hydraulic Power Pack LPP 7HA with C75 is recommended.



**Technical Specifications for LPP 6 HA C75 and LPP 7 HA C75**

LPP	LPP 6 HA C75	LPP 7 HA C75
Length, mm	895	940
Width, mm	900	985
Height, mm	730	780
Weight, kg	130	150
Hydraulic circuits, pcs	1	1
Hydraulic flow, l/min	3	10
Hydraulic pressure, bar	150	150
Power, kW	5.4	7.3
Hydraulic oil tank capacity, l	3	8
Fuel tank capacity, l	5	5
Delivery head, m	30	30
Suction lift, m	9.1	9.1
Wheels	Yes	Yes
Automatic shut down	Optional	Optional

**Features & Benefits**

- compact, multipurpose hydraulic power unit
- integrated oil transfer pump
- portable, on wheels
- can power Minimax skimmers, light boom reels
- capacity tested by Bureau Veritas



# Lamor Hydraulic Power-packs (LPP) 7, 14 and 16

The LPP 7 and 14 are used as a power source for the range of skimmers and smaller hydraulically operated equipment. The LPP 7 and 14 are equipped with a 7.3/14 kW air-cooled single cylinder diesel engine mounted in a mobile frame with wheels manufactured in tough tubular steel. The LPP 7 and 14 have two hydraulic circuits.

The LPP 7 and 14 represent a lightweight, easily portable power solution for hydraulic equipment that is operated in remote locations. For easy operation, electric start is standard with a manual start as back up. The LPP 7 and

14 can be equipped with spark arrestor and Chalwyn safety shut down valve. As an option the LPP 7 and 14 can be supplied in silent mode for environments where engine noise can be a problem.

Equipped with two hydraulic circuits, the LPP 16 can be used to power multiple users such as e.g. a skimmer and oil transfer pump simultaneously. The Lamor LPP 16 is containerized within a steel frame designed to ensure a good circulation for the water cooled diesel engine. The LPP 16 is equipped with electric start and incorporates an

easily accessible control panel and hydraulic oil cooler into the framework. The system is load sensing so the flow will always remain constant while the pressure varies according to consumption. For safety reasons, the hydraulic power-pack is equipped with an automatic shut down system. If a malfunction should occur, the engine operation will be shut down.







**Technical Specifications (Small)**  
A few examples of Lamors product range.

POWER PACK	LPP 7	LPP 14	LPP 16
Length, mm	945	930	1000
Width, mm	850	770	601
Height, mm	785	800	1000
Weight, kg	140	195	370
Hydraulic flow, l/min	28	39	50
Hydraulic pressure, bar	170	180	150
Power, kW	7.3	14	16
Wheels	Yes	Yes	No
Automatic shutdown	Optional	Standard	Standard

**Features & Benefits**

- lightweight, easily portable power solution
- well proven power source for a range of Lamor skimmers and smaller hydraulically operated equipment
- electric start as standard
- can be supplied in silent mode

## Lamor Hydraulic Power-packs (LPP) 23, 35 and 58

The LPP 23 is containerized within a steel frame designed to ensure a good circulation for the air cooled diesel engine. The power-pack is equipped with electric start (spring or hydraulic start optional) and incorporates control panel and hydraulic oil cooler in the framework and spark arrestor as standard.

The LPP 23 utilizes a proportional hydraulic valve system enabling easy adjustment of the flow of oil to the supplied components. The flow will always remain set even when the pressure varies according to consumption.

The LPP 23 is equipped with four point lifting rings and forklift channels mak-

ing it easy to handle on land or offshore. For safety reasons, the hydraulic power-pack is equipped with an automatic shut down system. If a malfunction should occur, the engine operation will be shut down.

## Lamor Hydraulic Power-packs (LPP) 77, 119, 150 and 200

The Lamor high capacity multipurpose power-packs are designed for the flexible operation of many types of hydraulically operated oil spill clean-up equipment. The 4/6-cylinder engines are an in-line design with full-authority electronic controls. A High Pressure Common Rail (HPCR) fuel system delivers greater power at every rpm. Together with vertically centered fuel injection and a symmetrical cylinder bowl, it produces exceptional low-end torque and power with reduced emissions and increased fuel efficiency. Additional torque and faster throttle response make it the perfect choice for many applications.

The engines are certified according to the following emission certificates:

U.S. EPA Tier 3, CARB Tier 3 and EU Stage IIIA. Equipped with 3-6/11 hydraulic circuits, the power-packs can be used to power multiple users such as pumps, skimmers and boom reels simultaneously.

The power-packs are containerized within a steel frame designed to ensure good air circulation inside the power pack frame. Four point lifting rings and forklift channels make them easy to handle on land or offshore. They are equipped with electric start and incorporate control panels and hydraulic oil coolers in the framework.

A PVG-100 Proportional Hydraulic Valve System enables easy adjustment of the flow of oil to the supplied components. The flow will always remain set even when the pressure varies ac-

ording to consumption. For safety reasons, the hydraulic power-pack is equipped with an automatic shut down system. If a malfunction should occur, the engine operation will be shut down. Optionally the hydraulics of the power-pack can be radio remote controlled.





**Technical Specifications**

A few examples of Lamors product range.

POWER PACK	LPP 23	LPP 35	LPP 58
Length, mm	1345	1330	1600
Width, mm	810	800	1050
Height, mm	1100	1000	1340
Weight, kg	530	570	900
Hydraulic flow, l/min	73	110	160
Hydraulic pressure, bar	180	180	210
Power, kW	23	35	58



**Technical Specifications**

A few examples of Lamors product range.

POWER PACK	LPP 77	LPP 119	LPP 150	LPP 200
Length, mm	2000	2300	2650	2650
Width, mm	1300	1400	1440	1440
Height, mm	1600	1800	1900	1900
Weight, kg	1480	2000	2300	2300
Power, kW	77	120	150	200
Hydraulic flow, l/min	230	320	315	420
Hydraulic pressure, bar	280	280	280	280

# Containerized System

Container 20 ft (with side and end doors)



**Lamor produces** a wide range of steel and aluminum containers that is developed based on years of experience on-scene in oil spill response (OSR) operations. The Lamor 20 foot container represents a turnkey solution for operators requiring OSR equipment.

The containers can be equipped with several door access options, retractable roof, hydraulically operated floors, air conditioning, heating and a wide variety of different furnish options. From tropical rain forests to the challenging Arctic, Lamor has the optimal containerized OSR solution that can be fully customized to any scenario or climatic conditions.

The container is adapted from a

new build certified for sea transport 20 foot ISO container for easy deployment offshore. In addition to transportation of the equipment the container is especially designed for storage and deployment of OSR equipment and customized outside colors are optional.

Inside the container is fitted with plywood floor or optionally a corrosion resistant non slip tread plate floor can be quoted. Four natural ventilation points with filters are fitted to ensure adequate air flow throughout the container. Fully furnished and insulated containers with heating and/or air conditioning can also be supplied.

Basic specification includes floor and ventilation grids. Shelving and tie

down points can be supplied according to individual needs.

## Technical Specifications

Length, mm	6050
Width, mm	2500
Height, mm	2590
Weight, kg	3250
Inner length, mm	5890
Inner width, mm	2330
Inner height, mm	2370
Capacity, m <sup>3</sup>	32.60

Fast deployment of containerized system.



### Brush skimmer and offshore oil boom system

Qty	Item	Qty	Item
1	Equipped Container 20 ft w / two (2) long side doors	6	Anchoring set for HDB 1200-1600
1	Retractable ISO Container Bed	1	Boom Repair Kit for HDB -1500
1	Fassi Crane F30CY/22	1	Boom Reel Heavy Construction HSR H 1817
1	Hydraulic Power Pack LPP 58 D/57cc	1	Hydraulic Hose Set for HSR L/H
1	Sparepart kit 1 for LPP 58	1	Hydraulic Air Blower HAB 200
1	Multi Skimmer LMS/GTA 50/70	1	Hydraulic Hose Set for HAB 200
3	Brush Module for LMS	1	Sparepart kit 1 for HAB 200
2	Hydraulic Hose Set for LMS	1	Heavy Duty Tool Box w. Consumables
1	Sparepart Kit 1 for LMS	2	Iron Rake w. Wooden Handle
1	Oil Transfer Pump GT A 50	2	Absorbent Boom LSB 20/3x4
2	Hydraulic Hose Set for GT A 50 H	2	Absorbent pad 19x17/100
6	Oil Transfer Hose Set for GT A 50 H	1	PVC Gloves K/W, Oil Resistant, 10 pack
1	Sparepart kit 1 for GT A 50	10	Safety goggles with soft temple tips
10	Hose float 800x300mm for 2" to 3" hoses	1	Disposable mask 50 pack
1	Hose Winder LHW 60/2-AI	1	Explosion Proof Flashlight
5	Heavy Duty Oil Boom HDB 1500/50m	3	4-point Certified Lifting sling LLS 4600/2.8
2	Towing set HDB 1500		

# 6 | CONTAINERIZED SYSTEM



Fast deployment of containerized system.



### Weir skimmer and offshore oil boom system

Qty	Item	Qty	Item
1	Equipped Container 20 ft w / two (2) long side doors	10	Hose float 800x300mm for 2" to 3" hoses
1	Retractable ISO Container Bed	1	Hose Winder LHW 60/2-AI
1	Fassi Crane F30CY/22	5	Heavy Duty Oil Boom HDB 1500/50m
1	Hydraulic Power Pack LPP 58 D/57cc	2	Towing set HDB 1500
1	Sparepart kit 1 for LPP 58	6	Anchoring set for HDB 1200-1600
1	Weir skimmer LWS 800/GTA 115	1	Boom Repair Kit for HDB -1500
1	Brush Adapter - Quattro for LWS 800	1	Boom Reel Heavy Construction HSR H 1817-C
2	Hydraulic Hose set for LBA-Q/LHS 3C	1	Hydraulic Hose Set for HSR L/H
1	Sparepart Kit 1 for LWS 800	1	Hydraulic Air Blower HAB 200
1	Spare part kit 1 for LBA-Q	1	Hydraulic Hose Set for HAB 200
1	Oil Transfer Pump GT A 115	1	Sparepart kit 1 for HAB 200
2	Hydraulic Hose Set for GT A 115 H	1	Heavy Duty Tool Box w. Consumables
6	Oil Transfer Hose Set for GT A 115 H	2	Iron Rake w. Wooden Handle
1	Sparepart kit 1 for GT A 115	2	Absorbent Boom LSB 20/3x4

# Lamor Landing Craft (LLC)

6500/7500/9000 Cabin and 10000 Cabin

**The main group** of the Lamor workboats made of seawater resistant aluminum comprises the low draft LLC design, with a self-draining deck and ranging in length from 6.5m-10.5m. The customer can specify engine type and drive; outboard, stern drive or water jet with diesel or gasoline engines.

The LLC features a bow ramp for easy access to open deck layout enabling effortless cargo handling. They are tailored to meet the demand for

tough, reliable and rapid work boats that meet customers' demanding and multi-task requirements. The low draft V-shaped hull ensures that the LLC handles extremely well even in rough seas. It is an ideal choice for boom handling operations and operates efficiently in oil spill response operations equipped with a Lamor Bow Collector.

In addition to the standard features of the vessel range, the LLC with Cabin is equipped with a weather proof cabin

fitted out with high quality components. The LLC Cabin is supplied with a wide range of standard equipment including hydraulic steering, navigation lights, bilge pump, mooring equipment etc.

Standard equipment include shore power supply, engine block heater and standard equipment in accordance with the Finnish Maritime Association (FMA) certification.







### Technical Specifications

A few examples of Lamors product range.

Landing Craft	LLC 6500 Outboard	LLC 7500 Cabin Stern Drive	LLC 9000 Cabin Stern Drive	LLC 10000 Cabin Stern Drive
Length, mm	6500	7500	9000	10000
Width, mm	2360	2600	3100	3000
Draft (with engine), mm	700	900	800	1000
Weight, kg	1500	2300	3200	5100
Carrying capacity, kg	1100	1710	2860	2960
Crew/passengers, persons	6	2/6	6	6
Power, hp	1 x 150 or 2 x 90	1 x 300	1 x 350 or 2 x 200	1 x 350 Or 2 x 200
Design Category	C-Inshore	C-Inshore	C-Inshore	C-Inshore

# Lamor Boom Towing Boat (LBTW) 9500

The **LBTW 9500** are specially designed for heavy duty working conditions in rough sea. The protective control station in the center of the vessel features good all-round visibility for the crew. Boom handling features, which were the main targets of focus when these vessels were designed, include characteristics such as high bollard pull of approx. 2.8 tons, good maneuverability, safe working conditions, quick release towing hook and reliable technical components.

The LBTW 9500 is designed to tow and push a variety of marine equipment and oil booms. The vessel is designed to work in coastal areas and outside sea ports or in connection to a mother ship. This vessel in seawater resistant aluminum is designed and constructed according to Nordic Work-

boats Standard (NBS), and is delivered with a recognized classification society's certificate.

To ensure an excellent maneuverability, the main propulsion system consists of two diesel engines connected through marine reduction gears and shaft arrangements to fixed-pitch propellers.

The vessel is capable of operating in 3 - 5 foot short interval seas in a minimum water depth of approx. 5 ft.

The LBTW 9500 is equipped with two diesel engines rated at 306 kW (410hp) @2100 rpm to reach 5 ton bollard pull. Coupling twin disk M G5075A2.88:1 SAE2. Exhaust will exit from stern and will be fitted with a properly sized muffler. Machinery is DNV certified. The engine is keel cooled. Navigational aids, electrical and

lighting systems are provided according to agreed certification.

A towing arm is installed on the aft deck, arm swivels approx. 117 degrees to insure safety of crew and vessel at a 5 metric tons pull. The towing arm is fitted with a manual safety release system (certified) that can be operated from inside the wheel house. The raised wheelhouse with swinging door access from aft deck is thermally insulated and equipped with console panel with operation and navigation equipment.

The dry weight of the boat is 8100 kg, operational weight with tanks full and crew of two is approx. 9150 kg. Four-point lifting arrangement with low lifting point (1850 mm above the deck) is included.





### Technical Specifications

LBTW	9500
Length, mm	9500
Width, mm	3300
Weight dry, kg	8100
Draft, mm	1300
Fuel tank capacity, l	300 l
Speed	15 knots
Power, hp	2 x 410 hp

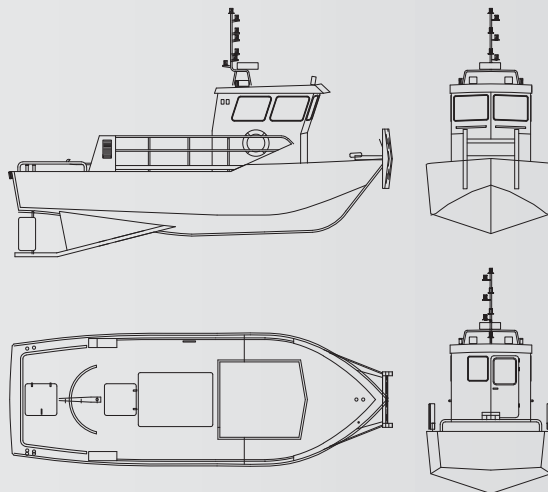

# Lamor Oil Recovery Boat (LORB) 15000

The 15 m long workboat with the built-in oil recovery system LORS on both sides handles recovery of oil and oil related products from near-shore, harbors, rivers, and channel areas while simultaneously cleaning-up small floating debris. The vessel is also ideal as a multipurpose vessel for boom deployment, dispersant spraying, and service tasks as well as a patrol boat.

The workboat has hull mounted brush packs which enables recovered oil to be delivered directly to the recovered oil storage tanks in the mid ship without the need of using oil transfer pumps. Another advantage is that the brush conveyors are in direct connection with the oil on the water surface, which especially improves the high viscous oil and debris collection capabili-

ties, as well as collecting of light oils.

The oil transfer pumps can be separately quoted for off-loading the oil, but can also be adapted to the skimmers e.g. to pump the collected oil to floating storage tanks or to a storage barge.

The vessel is designed with a covered hull built in steel marine grade. It is an even decked, unsinkable type of vessel, where a two compartment sized wheelhouse is located in the bow. An engine room, which is separated as a water resistant department, diesel power plant and shuttle propeller or traditional propeller propulsion installation is located in the stern.

The autonomy of the vessel with a cruising speed is two days. The unsinkable vessel is secured by dividing the

vessel with frame constructions into four water-tight compartments: fore peak, void room, tank for recovered oil and engine room. The vessel remains floating and maintains satisfactory stability during an emergency, if any compartment except for the engine room should fill up with water.

The maneuverability of the vessel is guaranteed by 300 degree turning shuttle propulsion equipment. Wheelhouse standard equipment; control panel, ergonomic pilot chair, mini pantry, shower, lockers, toilet, air condition/defrosting system and optionally 1 - 3 beds. Hull construction drawings are inspected by the Finnish Maritime Administration, based on the Nordic Boat Standard for work boats.



## Technical Specifications

LORB	15000
Length, mm	15000
Width, mm	5000
Weight dry, kg	26000
Draft, mm	2000
Fuel tank capacity, l	3000
Speed	10 knots
Power, hp	350

# Lamor Multipurpose Oil Recovery Vessel with Ice Class KM★ICE2 R3



The oil recovery vessel with the built-in oil recovery system LORS on both sides ( $2 \times 20 \text{ m}^3$ ) is usually custom built and designed pending the requirements. In addition to oil recovery, the workboat can also be used as a multi-purpose vessel for boom deployment, dispersant spraying, service tasks and as a safety patrol boat.

The vessel has hull mounted brush packs, which enables recovered oil to be delivered directly to the recovered oil storage tanks in the mid-ship without the need of using oil transfer pumps. Another advantage is that the brush conveyors are in direct connection with the oil on the water surface which notably improves the high viscous oil and

debris collection capabilities, but also collecting of light oils in Arctic conditions. Moreover, vessels are built to varying ice class demands and certified by the appropriate authorities in the region the vessel is used. Below is a brief extract of a general specification.

## Lamor Multipurpose Oil Recovery Vessel with Ice Class KM★ICE2 R3

### Designation of the boat

The technical support boat is used for the following purposes:

- oil spill response at sea
- cleaning water area from oil and floating garbage
- boom transportation and deployment
- loading and transportation of various goods with total weight up to 5 t

### Areas of operation

The boat shall operate in the water areas of Russian ports.

### Design type

Decked displacement-type flush-deck vessel made of steel, having a single deckhouse made of aluminum, and a hull divided by five transverse bulkheads into six water-proof compartments, and equipped with a twin diesel propulsion plant with shaft lines.

### Class of boat

The boat is designed according to the Russian Maritime Register of Shipping class KM★ICE2 R3

### General specifications

#### Main dimensions:

Length overall, m	19.0
Beam molded, m	5.3
Mid-ship depth, m	2.7
Loaded draft with cargo, m	about 1.2
Loaded draft with collected oil, m	about 1.6

#### Displacement

The loaded displacement is 93 t.

The navigation range at speed of 10 knots is not less than 200 miles.

The fresh water and victuals capacity provides a self-sustaining period of 3 days.

The deadweight of the boat at a summer load line draft is about 31 t. The cargo tanks have a total capacity of 20 m<sup>3</sup>.

The capacity of the consumable tank is as follows:

Diesel, m <sup>3</sup>	3.8
Fresh water, m <sup>3</sup>	1.0

The cargo hold has a capacity of about 11 m<sup>3</sup>.

The gross tonnage, as determined by the Register Rules, is about 50.

### Seaworthiness

Speed of a boat at conditions: fully equipped and without cargo, driven by its 2x330 kW main propulsion units at an engine speed of 1800 rpm, at maximum sea of 10 Beaufort, a wind speed of 20 Beaufort, at minimum water depth of 20 m and with a fouling-free hull, is about 10 knots. This speed must be performed at standard speed trials at measured course.

The propulsion unit provides any continuous speed within the whole speed range.

### Crew and accommodations

Boat crew consists of 2 persons.

A duty room shall be allocated for the crew on board and equipped with a food reheating facility.

During work emergency crew consisting of up to 4 members can be taken aboard.

### General arrangement and architecture

The boat has one deck and a single deckhouse at forward part. Five transverse watertight bulkheads divide the boat into six watertight compartments.

Fire protection meets the Rules of the Russian Maritime Register of Shipping.

### Special-purpose equipment

The following equipment is installed to provide the intended use of the boat:

- a beam crane
- a reel of 200 m of boom
- brush gears, fender booms and a control panel

All special-purpose units shall be actuated by hydraulics. For cargo handling operations, embarkation and debarkation of trash containers a crane-manipulator with a hydraulic drive is provided. Crane is mounted at the middle above a collected oil tank. A lifting capacity of the crane is 0.7 t at an outreach of 4.0 m. The boat is equipped with foam-filled boom Lamor FOB1 200 intended for use at wave height of up to 1 m.

Main particulars:

Class RMRS	KM Ice2 R3
Loa, m	19.0
Boa, m	5.3
Draft, m	1.6
Displacement, tons	93
Deadweight, tons	31
Speed	10 knots
Power, kW	2x330

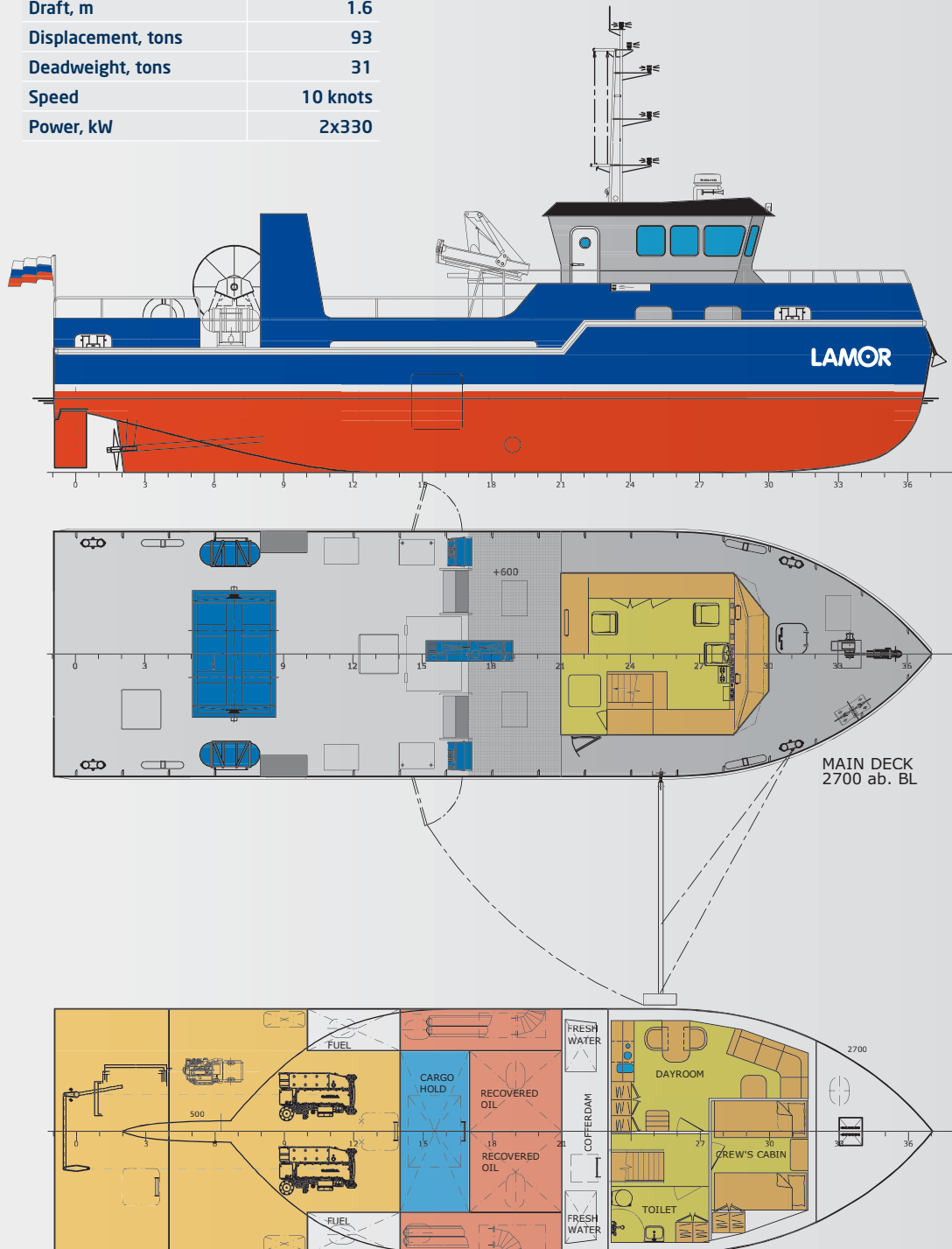

FOB1200 can be used in open water areas, at ports as well as for permanent installation in harbors and oil terminals.

The boom is stored on a hydraulically driven reel with capacity up to 200 m. The reel has rings on each corner to be hoisted by a crane.

The boom reel is placed astern above the machine compartment.

### Power plant

The power plant consists of:

- the main plant includes two Scania DI 12 59M marine four-cycle engines, with output of 330 kW at 1800 rpm, operating to fixed propellers
- an auxiliary power plant including a diesel generator of about 28 kW

### Propulsion units

The boat's propulsion unit consists of two main engines, transmission gears and fixed pitch propellers.

### Power station

Power sources:

- two main accumulators, each having 180 A/h, 12 V, connected in cascade
- two generators on the main engines, producing 28V, 65 A
- one three-phase diesel-generator of about 25 kW at 400 V, 50 Hz, with automatic voltage control and AREP -excitation
- two starter accumulators, each having 180 A/h, 12 V, connected in cascade, used to start the main diesels and the diesel generator
- two emergency accumulators, each having 180 A/h, 12 V, connected in cascade, used to power the electrical equipment in emergency

### Radio facilities

The following equipment is mounted aboard for the boat to navigate in A1 sea areas:

- a VHF radio set
- an emergency position radio buoy of the KOSPAS-SARSAT system
- radar transponder
- a VHF set of two-way radiophone communication

### Navigation equipment

The following equipment is mounted aboard to ensure safe navigation:

- a main magnetic compass
- a receiver-indicator for the radio navigation system
- a radar reflector
- a searchlight on a top of wheelhouse
- prismatic binocular
- hand lead
- inclinometer

### Onboard equipment

The boat is supplied with emergency, fire protection and navigation equipment in compliance with the RMRS Rules.

### Deployment of Lamor in-built oil recovery system (LORS).





# Lamor Multipurpose Workboat 18700

with Ice Class KM  ICE2 R3

Below is a brief extract of the general specification.

## General Description of the Boat

- The workboat is intended for transportation and placing of floating booms, conveyance of emergency crew and environmental equipment.
- The boat is of single deck enclosed type with deckhouse located forward.

## Main parameters

Length overall	18.7 m
Breadth	4.9 m
Draught	1.5 m
Depth	2.5 m
Displacement	54

Cargo hold capacity: 12 m<sup>3</sup>



### Crew

Crew consists of 6 persons.

### Endurance

The boat will be provided for 24 hours long sailing by stocks and fresh water and provisions for the crew and special personnel.

#### Propulsion, Speed and Consumption

The two main engines, e.g. SCANIA DI12 59M, are capable of developing a total maximum continuous rating MCR of amount 2x 330 kW.

- The full speed of the boat (trial speed) at draught of 1.4 m, at even keel, in deep water, in trial speed conditions will be at least 12 knots.

## Regulations and Classification

### Class Regulations

The boat is constructed according to RMRS Regulations of Classification and Construction of Seagoing crafts.

The vessel has the following class notation: Russian Navigation Register of Shipping, KM ICE2 R3.

### Interior Outfitting

- One three person cabin is provided below the deck. The cabin is equipped with kit lockers, three beds, chair and cabinet.
- A toilet/washing room will be provided.

### Machinery

The boat power plant consists of a main power plant intended for ensuring movement and maneuvering of the boat and an auxiliary power plant intended for supplying the boat with electric power. Diesel fuel and motor oil of SAE 30 or SAE 40 viscosity class will be used to operate main engines and auxiliary engines.

### Main Diesel Engines

- Main power plant consists of two main engines located in the engine room.
- Main engines are completed with all necessary control and monitoring devices, air filters, heat exchangers, pumps, fine fuel filters and preliminary fuel filters with water separation and oil filters.
- Main engines meet IMO 2000 requirements regarding NOx emissions.
- Specific fuel consumption rate at the maximum power is approx. 200 g/kWh and in the saving mode approx. 195 g/kWh.
- Power-speed prediction is introduced.

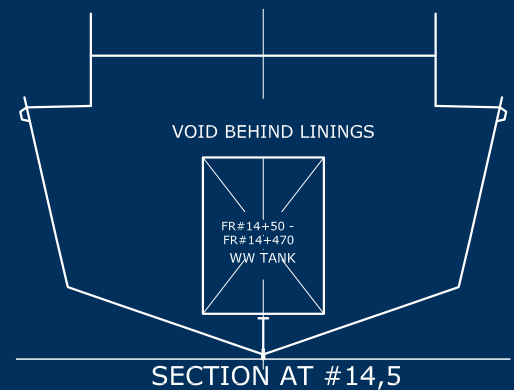
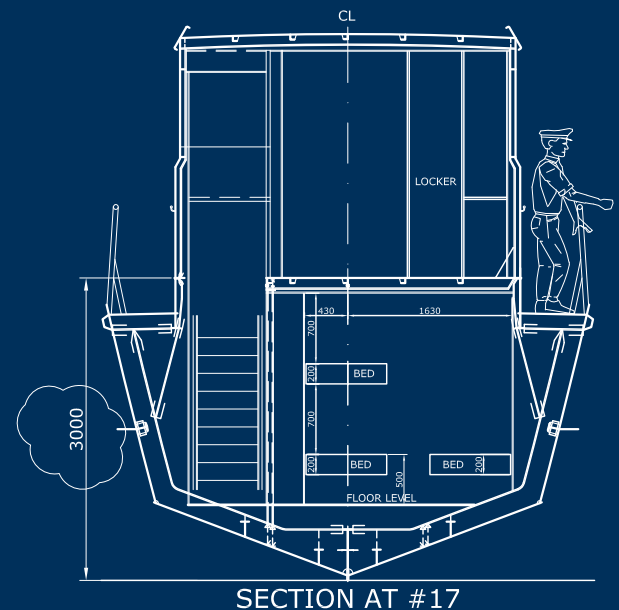

Main particulars:

Class RMRS	KM Ice2 R3
Loa, m	18.7
Boa, m	4.9
Draft, m	1.5
Draft Ice Max	
Ta (aft), m	1.6
Tf (fore), m	1.5
Displacement, tons	54
Speed	10-12 knots
Power, kW	2x331
Ice class	ICE 2
Service area	R3

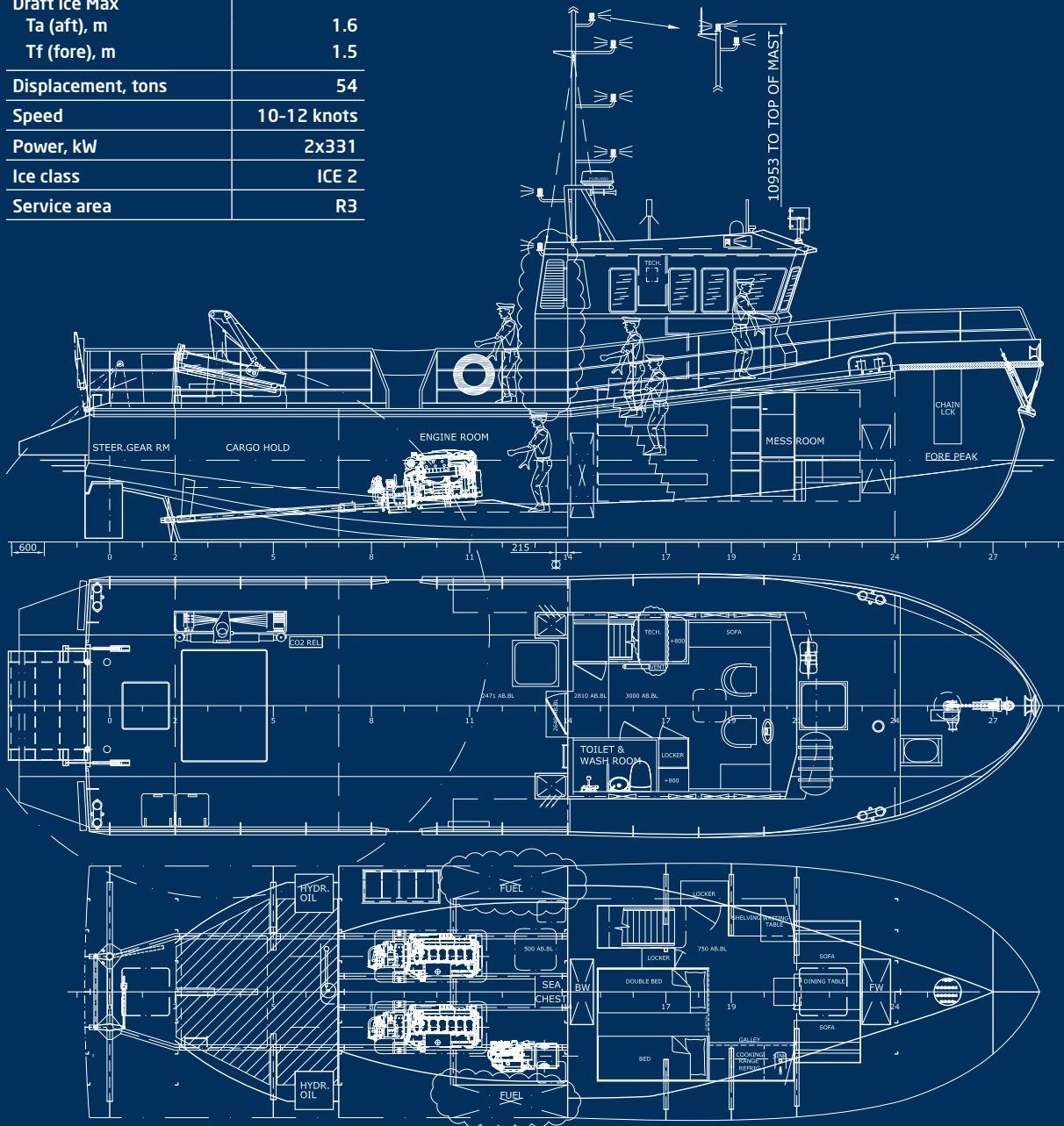

### Propulsion System

- The vessel is fitted with a two fixed pitch propellers.
- Two reduction gears and propulsion axle lines are provided.

### Auxiliary Engines

- Auxiliary power plant consists of a marine diesel generator Nanni Diesel GE V-3300 with power of 26 kW under ambient conditions in accordance with ISO 3046.
- Diesel generator is complete with all necessary control and monitoring devices. The diesel generator is electrically started.

### Electrical Installation

The whole ship's electrical installations are designed and installed according to the specified Rules in this specification and Builder's standards. Materials are in accordance with Maker's standard.

### Supply Voltages

Item	Voltage (V)	Phase	Frequency (Hz)
Shore connection	380	3	50
Generators	380	3	50
Lighting	230/24		50/DC
Radio, loudspeakers	24		DC

### Electric Power Generation

The following is considered as the primary source of electric energy on the boat:

- One diesel generator with output of abt. 20 kW providing power for all necessary equipment in all operating modes of the boat. The diesel generator is installed in the engine room. Diesel generators will be electrically started from a starter battery room. AB recharging is provided from diesel generator charging generator.

### Navigation and Communication System

Following navigation equipment is installed on the boat:

- Steering magnetic compass
- Receiver-indicator FURUNO
- Radiolocation station FURUNO

### Radio Equipment

Radio stations and radio facilities by FURUNO complying with GMDSS requirements for conventional equipment for sea area A1 is installed.

Radio equipment is located in the wheelhouse. Antenna assembly



is installed on the wheelhouse top and on the mast.

Following (or similar) radio facilities that meet requirement:

- VHF-set (with a digital selective calling device (DSC) of 25 W emission power
- Radar responder and Epirb
- Portable VHF radiotelephone station, 2 kits
- Supply to radio equipment from 24 V direct current circuit.

### Automation and Control

Controls, indications and alarms of boat's systems will be arranged as described in this specification. A control console will be provided in the wheelhouse at least for the following systems:

- Fire smothering
- Bilge water
- Fresh water
- Deck drain
- Ventilation
- Fire detection
- Machinery control



<b>Units</b>	
barrel	42 U.S. gallons
gallon	0.02838 barrel
centimeter	0.3937 inch or 0.0328 foot
inch	2.54 centimeters
meter	3.28 feet
foot	30.48 centimeters
cubic meter	35.31 cubic feet
cubic foot	0.02832 cubic meters
kilometer	0.622 mile
mile	1.609 kilometers
square meter	1.196 square yards
square yard	0.8361 square meter
kilogram	2.2 pounds or 37.27 ounces
ounce	0.02835 kilogram
pound	0.454 kilogram
knot	1.151 miles per hour
horsepower	0.746 kilowatt
kilowatt	1.341 horsepower
<b>Volumes of oil</b>	
barrels x 42	U.S. gallons
barrels x 35	imperial gallons
U.S. gallons x 0.833	imperial gallons
U.S. gallons x 3.785	liters
U.S. gallons x 0.0238	barrels
U.S. gallons x 0.0034	metric tons
metric tons x 294	U.S. gallons
cubic meters x 264.2	U.S. gallons
cubic feet x 7.481	U.S. gallons
<b>Areas</b>	
acres x 0.004047	square kilometers
acres x 0.4047	hectares
square kilometers x 0.386	square miles
square miles x 2.59	square kilometers
<b>Linear distances</b>	
meters x 3.21	feet
nautical miles x 1.1516	statute miles
nautical miles x 6.076	feet
nautical miles x 1.852	kilometers
kilometers x 0.6214	statute miles
<b>Temperature conversions</b>	
$(^{\circ}\text{F} - 32) \times 5/9$	$^{\circ}\text{C}$
$(^{\circ}\text{C} \times 1.8) + 32$	$^{\circ}\text{F}$
<b>Speed conversions</b>	
knots x 1.852	kilometers/hour
knots x 1.151	statute miles/hour
miles (statute)/hour x 0.8684	knots
<b>Pressure conversions</b>	
bar	14.5 pounds per square inch (psi)
psi	0.06895 bar
kilopascal (kPa) = 0.01 bar	0.145 psi
<b>Water at 39.2 °F (=4 °C)</b>	
100 psi (6.895 bar)	2768 inches (70.31 meters)
<b>Atmosphere</b>	
100 psi (6.895 bar)	6.805 atm

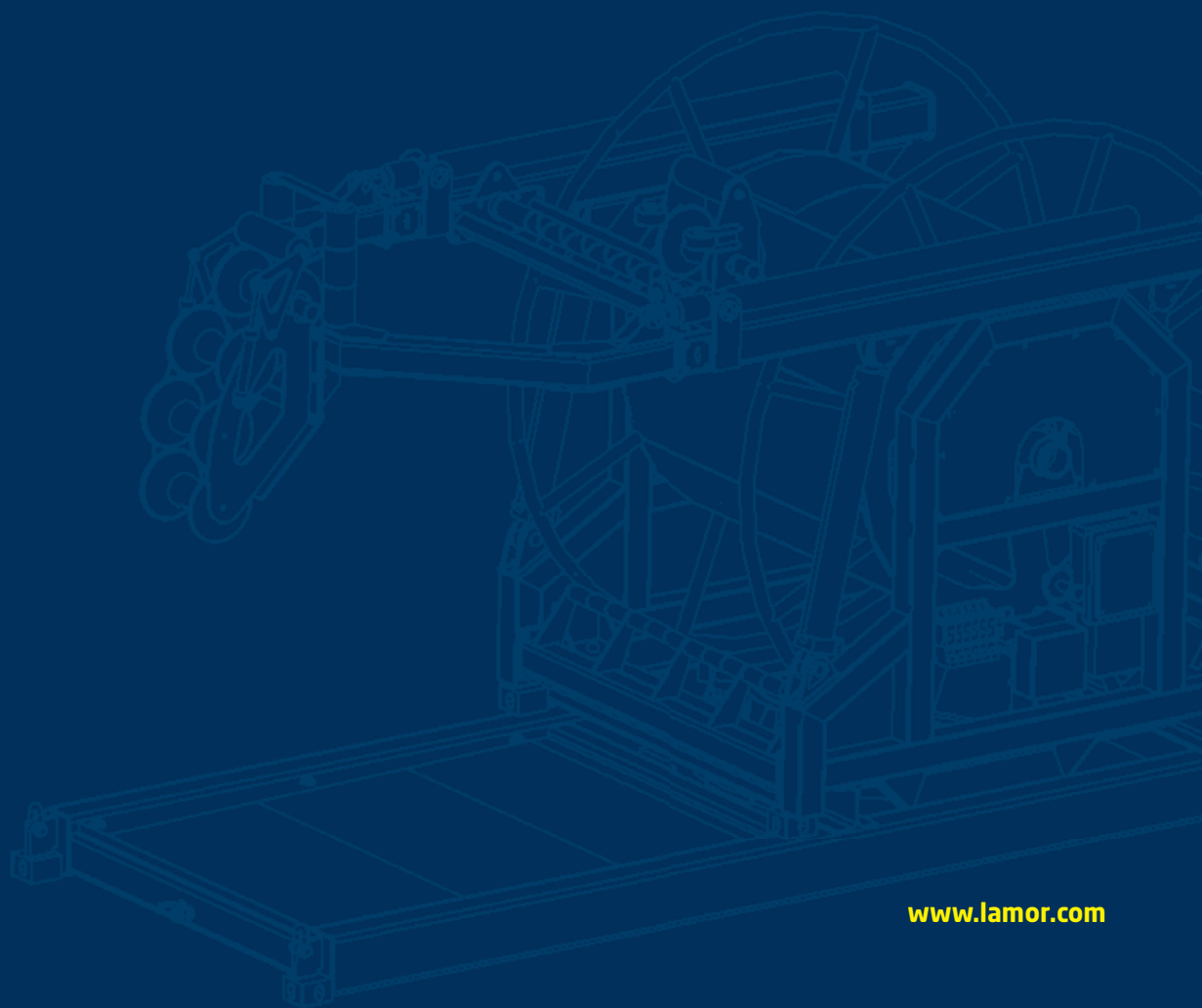



Lamor Next Generation Skimmer (LNxG 100)

# LAMOR

## Lamor Finland

Urakoitsijantie 12  
06450 Porvoo, Finland  
tel: +358 20 765 0100  
fax: +358 20 765 0129  
email: info@lamor.com

## Lamor USA

18 Beach Street  
Seymour, CT 06483  
United States  
Tel: +1 203 888 7700  
Fax: +1 203 888 7720  
Email: info@lamor.com

## Lamor UK

3 Medina Court, Arctic Road  
Cowes, Isle of Wight, PO31 7XD,  
United Kingdom  
Tel: +44 1983 280 185  
Fax: +44 1983 280 056  
Email: uk.info@lamor.com

## Lamor China

Xianguangli No. 66  
Chaoyang District  
100027 Beijing, China  
Tel: +86 10 8446 7400  
Fax: +86 10 8446 7440  
Email: info@lamor.com.cn

[www.lamor.com](http://www.lamor.com)